

9 MILLION LIFE CYCLE

The HJFC Hall Effect Foot Pedal is built to perform under the worse possible conditions. The unique design places Hall sensors and electronics behind a solid plastic diaphragm that separates the top and bottom halves of the front pedal, sealing the electronics in an IP68 rated enclosure. The bottom half of the pedal utilizes the same proven non contacting analog output Hall technology used in the OTTO Joystick and is available in J1939 and CAN Open formats. It provides 8 analog input channels, 13 digital input channels, 2 digital output channels and I/O extension for up to 40 digital input channels and 8 analog input channels by means of I2C interface. It will withstand operating temperature extremes of -40 C to +85 C is sealed to IP68 immersion requirements and passes EMI/RFI immunity testing to 100 Volts/ meter.

The HJFC Foot Pedal provides a life expectancy of over 9 million cycles. The pedals pivot point itself is also sealed against large debris. Customer specified features such as pre-travel (dead band) and over travel along with a minimum and maximum output are programmable. The sensor programming is completed in automated fixtures during assembly ensuring tight output tolerances. The HJFC Foot Pedal offers more performance features, a higher cycle and seal rating than any other foot pedal in the market.

## Quality Features:

- Outstanding EMI/RFI immunity
- Heavy gauge, corrosion resistant metal
- Proven non-contacting analog output Hall technology
- Life expectancy of over 9 million cycles
- Hall sensors and electronics behind a solid plastic diaphragm that separates the top and bottom halves of the foot pedal
- Enclosure sealing IP68 rated enclosure
- Pedal pivot point sealed against large debris
- Programmable pre-travel (dead band) and over-travel along with minimum and maximum output
- Sensor programming is completed in automated fixtures during assembly ensuring tight output tolerances
- Reverse Polarity Protection available



STANDARD CHARACTERISTICS/RATINGS:			
<b>MECHANICAL</b>			
Mechanical Life:	9,000,000 cycles		
<b>TRAVEL ANGLE</b>			
Degrees	12	13	14
Operating force LBS	10	12	14
-40 - +85° C at load reference point at 6.5° of travel			
<b>ENVIRONMENTAL: MIN TYP MAX</b>			
Operating Temp:	°C -40	20	85
Storage Temp:	°C -65	20	105
Humidity:	96% RH, 70°C, 96 hrs		
<b>ELECTRONICS</b>			
Seal:	IP68		
RFI:	Withstand 100V/M, 14KHz, to 1GHz		
EMC:	Withstand per MIL STD 461D/SAE J1113-22		
Sand and Dust:	Withstand per SAE J1455		
<b>MATERIAL</b>			
Foot Pedal Plate:	Zinc & High Corrosive Trivalent Chromate		
Housing:	PPE/PA		
Cable:	#22AWG PVC/Polyurethane blend outer jacket		

	HJFC	-	X	X	X	X	X	X	X	X
<b>Direction</b>	1 Single									
<b>Travel</b>	1 15 Degrees Single Direction									
<b>Output</b>	1 Single Direction Analog Output (Rest/Full) 0.5-4.5 VDC									
<b>Sealing</b>	1 Fully Sealed									
<b>Power</b>	1 Requires 5V Clean Supply, No Reverse Polarity Protection									
<b>Termination</b>	1 .225" Diameter 12" Cable, Unterminated									
<b>Pedal</b>	1 Narrow Mounting									
	2 Dual									
	2 13 Degrees Dual Direction									
	2 Dual Direction Analog Output (REV/CTR/FWD) 0.5-2.5-4.5									
	2 Unsealed									
	3 Dual Direction Analog Output (REV/CTR/FWD) 0.5-2.5-4.5 and Dual Direction Position Indication									
	3 Plate Seal									
	4 Dual Direction Dual Analog Output 1: (CTR/FWD): 0.5-4.5 Output 2: (REV/CTR): 4.5-0.5									
	4 Shaft Seal									
	5 Single Direction Analog Output (Rest/Full) 0.5-4.5 VDC and Single Directional Position Indication									
	6 Single Direction Dual Analog Output Output 1: (Rest/Full): 0.5-4.5 VDC Output 2: (Rest/Full): 4.5-0.5 VDC									

\*\* NOTE: Single Direction Not Available in Narrow Mounting.

# HALL EFFECT FOOT PEDAL

**DUAL DIRECTION**

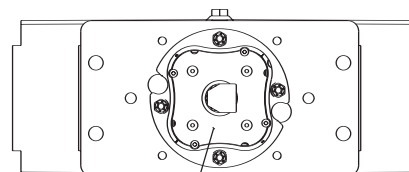
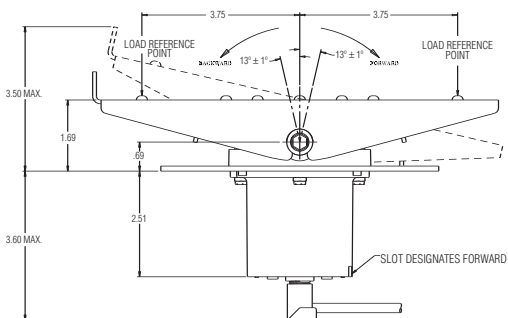
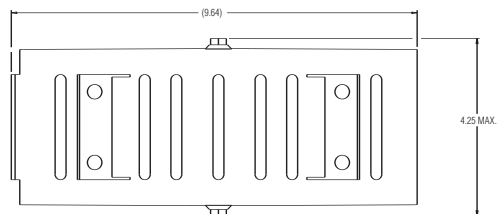
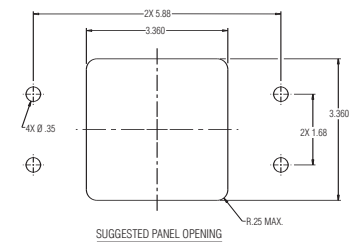
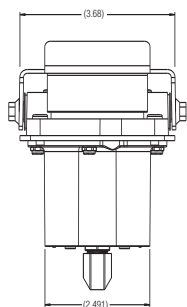

MARKING ON BOTTOM PLATE:  
PART NUMBER  
OTTO 21649  
DATE CODE (YYWW)

Narrow mounting version shown

Option 3

Option 2

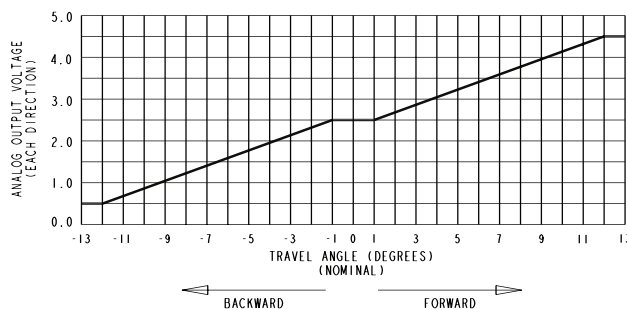
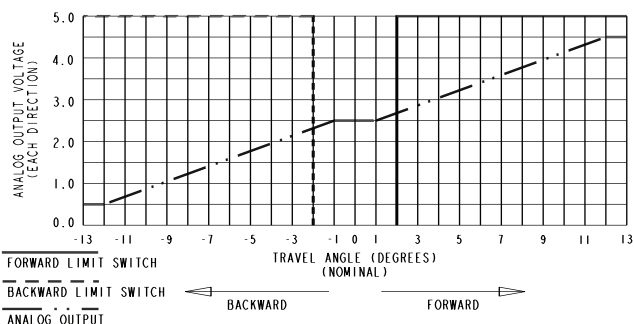

**SINGLE DIRECTION**

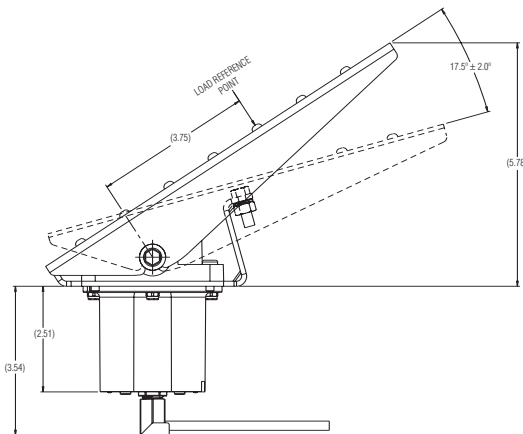
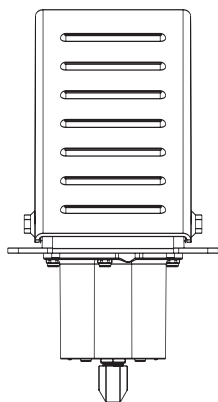
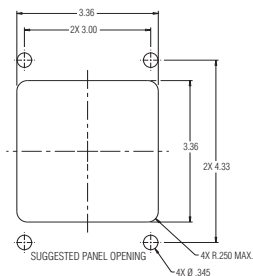

Option 1

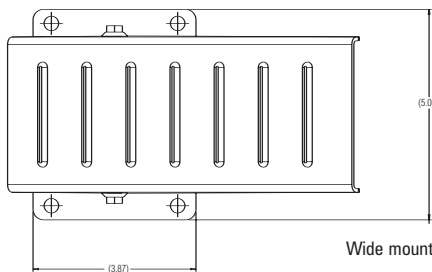
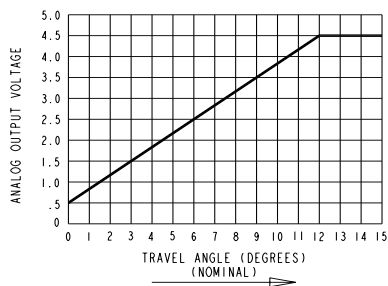

Wide mounting version shown