

LED INDICATOR

THREE LEAD BI-COLOR REAR-MOUNT



Model ML1635

Developed for use as a status indicator, the ML1635 was designed to survive in the most severe environments. The small size and rugged package make it ideal for applications where status indication is critical to the operation of your equipment. The environmentally sealed case includes an O-ring panel seal that insures the integrity of your system. Comes complete with Fluorosilicone O-ring and mounting hardware.



ML1635E

Case with EMI Screen

FEATURES

- Multiple status indication within a single package
- Environmentally sealed
- Panel mount seal
- Colors: red/green & yellow/green
- Compact case design
- EMI screen option
- Decorative bezel

MECHANICAL SPECIFICATIONS

Case: Aluminum, black anodized, standard. Clear chromate case with EMI screen option.

Mounting: Rear-mount by 5/16"-32 nut and lockwasher

O-ring: Fluorosilicone rubber

ENVIRONMENTAL SPECIFICATIONS

Vibration: .06" D.A. or 20 Gs Peak, whichever is less, 10Hz to 2kHz, MIL STD 202, Method 204, Test Condition D

Shock: 100 Gs MIL STD 202, Method 213, Test Condition I

Moisture Resistance (Humidity): MIL STD 202, Method 106

Barometric Pressure (Reduced): 100,000 ft., MIL STD 202, Method 105, Test Condition D

Reliability: 3 x 10⁶ hours min. MTBF @ 25°C

Salt Atmosphere (Corrosion): MIL STD 202, Method 101, Test Condition B

ELECTRO-OPTICAL CHARACTERISTIC SPECIFICATIONS

Absolute Maximum Ratings @Temp = 25°C				
Color	Red / Green		Yellow / Green	
Forward Voltage (VDC) typical @ 20 mA	2.0	2.1	2.0	2.1
DC Forward Current (mA)	30	25	30	25
Reverse Voltage (VDC) @ I _R = 100 μA	5	5	5	5
Power Dissipation (mW) ①	100	105	105	105
Luminous Intensity (mcd) typical @ I _F = 20 mA DC	Diffused		200	60
Dominant Wave Length (nm) typical	630	570	588	570
Viewing Angle	Diffused		60°	
Operating Temperature (°C)	-40 to +85			
Storage Temperature (°C)	-40 to +85			
Lead Soldering Temperature	260°C for 5 seconds			

Notes: ① Derate linearly from 25°C at -1.2 mW/°C

This page consists of basic marketing information that is not defined as technical data under FAR Part 772.

LED INDICATOR

THREE LEAD BI-COLOR REAR-MOUNT



ORDERING INFORMATION

When ordering, show model number first, followed by EMI screen, then LED color, lens style, and terminal style. If this is a special part, a factory assigned modification number will be added at the end of the ordering number. Consult the factory for special configurations.

Example: Basic model with an EMI screen, with a yellow/green LED, a diffused lens, and straight leads would be ML1635E-SY/SG-D-ST.

ML1635E - SY/SG - D - ST - ()

Standard factory options are designated by "-Sxxx"

Basic Model Number	EMI Screen	LED Color	Lens Type	Terminal Style
ML1635	() None E Screen	SR/SG Red/Green SY/SG Yellow/Green	D Diffused	ST Straight Leads

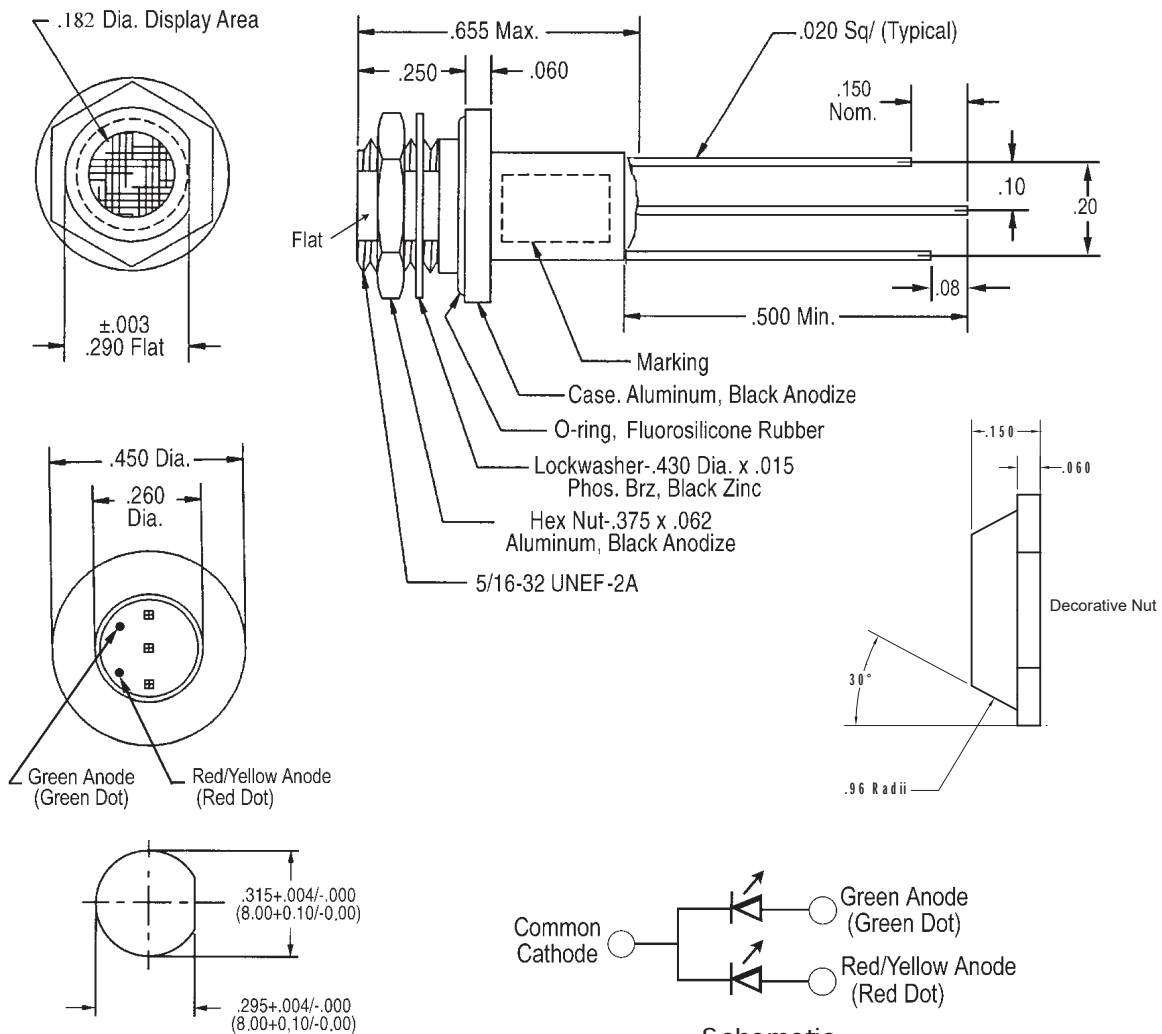

Recommended Mounting Hole

Schematic

ML1635

NOTE: Dimensions in () are mm. Tolerances: Decimals: ± .010 (0.25)
Fractions: ± 1/64 Mounting Torque: 5-7 in. lbs.

This page consists of basic marketing information that is not defined as technical data under FAR Part 772.