

## Electromechanical & Solid-State Elapsed Time Indicators and Event Counters Contents

<b>DC SERIES ELAPSED TIME INDICATORS</b>	<b>75</b>	<b>EVENT COUNTERS</b>	<b>77</b>
10 to 34 VDC models 16 and D16	75	28 VDC Model B16	77
4.5 to 6.5 VDC model D46	75	28 VDC Model L16 Ruggedized	77
Standard Case and Mount Information	78	Standard Case and Mount Information	78
Standard and Straight Pin Headers	79	Standard and Straight Pin Headers	79
<b>AC SERIES ELAPSED TIME INDICATORS</b>	<b>76</b>	<b>CUSTOM ENCLOSURES</b>	<b>80</b>
100-130V/380-420Hz Model D95	76	999A Series	80
20-40V/45-70Hz Model D21	76	<b>MIL SERIES</b>	<b>81</b>
15-40V/380-420Hz Model D25	76	Military Elapsed Time Indicator Guide	81
100-130V/50-70Hz Model D92	76	Military Cross Reference	82-84
75-150V/50-400Hz Model D91	76	<b>DIGITAL SERIES</b>	<b>86</b>
Standard Case and Mount Information	78	Solid-State Elapsed Time Indicators & Event Counters	86-91
Standard and Straight Pin Headers	79	Model 1170-004 SSETI Reader	92

This page consists of basic marketing information that is not defined as technical data under FAR Part 772.

# ELAPSED TIME INDICATORS

## DC SERIES: SUBMINIATURE



### Models 16, D16 & D46

See the Military Cross Reference for military qualified models, page 82.

The ElectroDynamics DC meter was developed to meet the difficult requirements of most military and aerospace applications. They provide a wide range of supply voltage options and are packaged in a hermetically sealed miniature enclosure. This rugged design meets or exceeds an array of tough environmental specifications including shock, vibration, and temperature. A variety of mounting configurations are available as shown on pages 78 and 79. We also welcome inquiries for special requirements.

### FEATURES

- Rugged design
- Hermetically sealed
- Low voltage models available

### MECHANICAL SPECIFICATIONS

**Case:** Copper-nickel or brass, with durable black finish. E and F mounts are nickel-plated case with black face.

**Max. case length:** Short version: 1.094 in.  
Long version: 2.082 in.

**Flange:** Brass

**Terminals:** Solder hook

**Weight:** 0.4 ounces maximum without mount  
0.6 ounces maximum with C flange

**Numerals:** .035" wide, .078" high. Hour digits are white on black. Tenths are red on white.

### ENVIRONMENTAL SPECIFICATIONS

**Operating Temperature Range:** -65 to +125°C

**Shock:** MIL-STD-202, Method 213, Condition I

**Vibration:** MIL-STD-202, Method 204, Condition D



**ESD Susceptibility:** Classified as Class 3 ESD sensitive in accordance with MIL-STD-1686

### ELECTRICAL SPECIFICATIONS

Meters meet or exceed applicable requirements of MIL-DTL-7793 M7793/1, /2, /5 and MS21341 A & B. Special ratings and configurations are also available.

**Transient Protection:** MIL-STD-704A, 80 & 600 V (Models 16 & D16)

**Ripple Protection:** MIL-STD-704A, para. 5.2.2 to 5.2.2.1 & Fig. 7 (Models 16 & D16)

**Dielectric:** 350 VRMS @ 80,000 ft., 600 VRMS @ sea level

**Insulation Resistance:** MIL-STD-202, Method 302, Condition B

**Accuracy:** 0.1% over temperature/voltage range

**Power Consumption:** D16 & 16 = .085 Watts, D46=.010 Watts

**Reading Allowed at time of Shipments:** Meters can be delivered with +/- 1 hour upon delivery per MIL-DTL-7793

### ORDERING INFORMATION

When ordering, show model number first (D), then operating voltage, case type, maximum hours (4 or 5 digit), mount type, and mount setback desired. If this is a special part, a factory modification number will be added at the end of the ordering number. This order chart lists standard features. Other ratings and configuration are also available. Example: D16C8CE-136

Case Length	Operating Voltage	Case Type	Maximum Hours 4 Digit / 5 Digit	Mount Type	Mount Setback	Standard Factory Code* Description	Option Examples
D = Short	16 = 10-34 VDC	B = 4 Digit Round	3 = 999.9 / N/A	A = No Mount	A = Flush	1 Rotated 90° type C, C7, V, W mount	
( ) Long ①	46 = 4.5-6.5 VDC②	C = 4 Digit Square	8 = 9999 / 9999.9	Others available, see page 78	B to Z See "Table A" on page 81 for "X" Dimensional Code desired	14 4-40 Clinch Nuts, for type C mount	
	Other voltages also available	D = 4 Digit Square (Side-Read)	9 = N/A / 999999			16 Tin-plate front of mount, type C mount	
		G = 5 Digit Rect.				136 Tin-plate front of mount, type C (M7793/1 & /2), C7, V & W	

① Omit "D" for long case      ② 5 VDC not MIL qualified

This page consists of basic marketing information that is not defined as technical data under EAR Part 772.

# ELAPSED TIME INDICATORS

## AC SERIES: SUBMINIATURE



ELAPSED TIME INDICATORS & EVENT COUNTERS

### Models D21, D25, D91, D92 & D95

See the Military Cross Reference for military qualified models, pages 82-84.

The AC meter was developed to meet the most difficult requirements of many military and aerospace applications. Available in 50Hz, 60Hz and 400Hz configurations, the AC series meters meet or exceed an array of tough environmental specifications including shock, vibration, and temperature. A variety of mounting configurations are available as shown on pages 78 and 79. We also welcome inquires for special requirements.

#### FEATURES

- Rugged design
- Hermetically sealed

#### MECHANICAL SPECIFICATIONS

**Case:** Copper nickel or brass, with durable black finish. E and F mounts are nickel-plated case with black face.

**Max. case length:** Short version: 1.094 in.  
Long version: 2.082 in.

**Flange:** Brass

**Terminals:** Solder hook

**Weight:** 0.4 ounces maximum without mount  
0.6 ounces maximum with C flange

**Numerals:** .035" wide, .078" high. Hour digits are white on black. Tenths are red on white.

#### ENVIRONMENTAL SPECIFICATIONS

**Operating Temperature Range:** -65 to +125°C

**Shock:** MIL-STD-202, Method 213, Condition I

**Vibration:** MIL-STD-202, Method 204, Condition D

#### ORDERING INFORMATION

When ordering, show model number first (D), then operating voltage, case type, maximum hours (4 or 5 digit), mount type, and mount setback desired. If this is a special part, a factory modification number will be added at the end of the ordering number. This order chart lists standard features. Other ratings and configuration are also available. Example: D95C8CE-16



**ESD Susceptibility:** Classified as Class 3 ESD sensitive in accordance with MIL-STD-1686

#### ELECTRICAL SPECIFICATIONS

Meters meet or exceed applicable requirements of MIL-M-7793 M7793/3, /4, /6, /8, /9, /10 (if QPL'd) MS27650 & 27651. Special ratings and configurations are also available.

**Transient Protection:** As applicable, 180 VRMS up to 0.15 seconds

**Dielectric:** 350 VRMS @ 80,000 ft., 600 VRMS @ sea level

**Insulation Resistance:** MIL-STD-202, Method 302, Condition B

**Accuracy:** 0.1% over temperature/voltage range

**Power Consumption:**

D21 & D25 = .015 Watts

D91, D92, & D95 = .3 Watts

**Reading Allowed at time of Shipments:** Meters can be delivered with +/- 1 hour upon delivery per MIL-DTL-7793

D 95 C 8 C E - 16

Case Length	Operating Voltage	Case Type	Maximum Hours 4 Digit / 5 Digit	Mount Type	Mount Setback	Standard Factory Option Code*	Examples Description
D	21 = 20-40 VAC/ 45-70 Hz	B = 4 Digit Round	3 = 999.9 / N/A	A = No Mount	A = Flush	1	Rotated 90° type C, C7, V, W mount
D	25 = 15-40 VAC/ 380-420 Hz	C = 4 Digit Square	8 = 9999 / 9999.9	Others available, see page 78	B to Z See "Table B Mount Setback Data" on page 81 for "X" Dimensional Code desired	14	4-40 Clinch Nuts, for type C mount
D	91 = 75-150 VAC/ 50-400 Hz	D = 4 Digit Square (Side-Read)	9 = N/A / 99999			16	Tin-plate front of mount, type C mount
D	92 = 100-130 VAC/ 50-70 Hz	G = 5 Digit Rect.				136	Tin-plate front of mount, type C (M7793/1 & /2), C7, V & W
D	95 = 100-130 VAC/ 380-420 Hz						*See "Table C Standard Options" on page 81 for all codes

This page consists of basic marketing information that is not defined as technical data under FAR Part 772.

# EVENT COUNTERS SUBMINIATURE



## Models B16 & L16 Ruggedized

MIL-I-8974 Equivalent Part Numbers	
Mil Spec	L-3 EDI Commercial
M8974/2-003*	B16C8A-232
M8974/2-004*	B16C8CE-232

**\*MIL Spec numbers are no longer available**

The ElectroDynamics subminiature event counters were designed to meet the most difficult requirements of many military and aerospace applications. These rugged counters meet or exceed an array of tough environmental specifications including shock, vibration, temperature and are packaged in a hermetically sealed miniature enclosure. A variety of mounting configurations are available as shown on pages 78 and 79. We also welcome inquires for special requirements.

The ruggedized event counters are assembled and filled with a dielectric lubricant that dampens the effects of extreme vibration and thermal shock.

### FEATURES

- Rugged design
- Hermetically sealed

### MECHANICAL SPECIFICATIONS

**Case:** Copper-nickel or brass, with black face. E and F mounts are nickel-plated case with black face.

**Max. case length:** 1.094 in.

**Flange:** Brass

**Terminals:** Solder hook

**Weight:** Standard: Will not exceed 1.2 ounces with C flange  
Ruggedized: Will not exceed 1.8 ounces with C flange

**Numerals:** .035" wide, .078" high. All digits are white on black.

### ORDERING INFORMATION

When ordering, show model number first (B), then operating voltage, case type, maximum counts (4 or 5 digit), mount type, and mount setback desired. If this is a special part, a factory modification number will be added at the end of the ordering number. This order chart lists standard features. Other ratings and configurations are also available. Example: B16C8CE-1

Model Number	Operating Voltage	Case Type	Maximum Hours Maximum Event 4,5,&6 Digit	Mount Type	Mount Setback	Standard Factory Option Code*	Examples Description
B = Standard	23-29 VDC	C = 4 Digit Square	8 = 9999	A = No Mount	A = Flush	1	Rotated 90° type C, C7, V, W mount
L = Ruggedized	18-32 Others available	G = 5 Digit Rect	9 = 99999	Others available, see page 78	B to Z See "Table A" on page 81 for "X" Dimensional Code desired	14	4-40 Clinch Nuts, for type C mount
		F = 6 Digit Rect.	6 = 999999			136	Tin-plate front of mount, type C, C7, V & W

\*See "Table C Standard Options" on page 81 for all codes



### ELECTRICAL SPECIFICATIONS

**Polarity:** Not polarity sensitive

**Dielectric:** 500 VRMS @ 80,000 feet

**Insulation Resistance:** MIL-STD-202, Method 302, Condition B

### ENVIRONMENTAL SPECIFICATIONS

**Operating Temperature Range:** Standard: -65 to +125°C  
Ruggedized: -55 to +125°C

### STANDARD RATINGS

**Count Rate:** 5 Counts/Second

**Minimum Impulse Time:** 50ms / 150ms off

**Thermal Shock:** MIL-STD-202, Method 107, Condition B

**Shock:** MIL-STD-202, Method 213, Condition A

**Vibration:** MIL-STD-202, Method 204, Condition D except at 10 Gs max.

**Life:** One million counts @ 25°C

### RUGGEDIZED RATINGS

**Count Rate:** 5 Counts/Second

**Minimum Impulse Time:** 50ms / 150ms off

**Thermal Shock:** MIL-STD-202, Method 107, Condition B, except temperature -55 °C to +125 C

**Shock:** MIL-STD-202, Method 213, Condition A

**Vibration:** MIL-STD-202, Method 204, Condition D

**Life:** 5 million counts @ 25°C

### POWER CONSUMPTION (for Standard & Ruggedized):

4 digit oil filled: 3.4 Watts max. @ 28VDC  
4 digit dry: 1.5 Watts max. @ 28VDC  
5 digit oil filled: 3.4 Watts max. @ 28VDC  
5 digit dry: 2.5 Watts max. @ 28VDC  
6 digit dry: 2.5 Watts max. @ 28VDC

This page consists of basic marketing information that is not defined as technical data under EAR Part 772.

ELAPSED TIME INDICATORS & EVENT COUNTERS

# ELAPSED TIME INDICATORS AND EVENT COUNTERS



ELAPSED TIME INDICATORS & EVENT COUNTERS

## Standard Cases & Mounts

Recommended mounting torque: 2 in. lbs.\*

Recommended Panel Cut-Out:  
.562" (9/16") X .562" (9/16"), 4 Digit

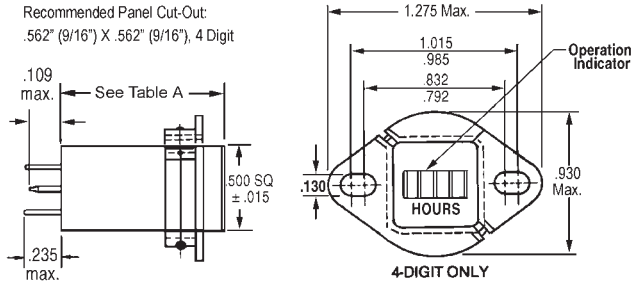

**Figure 1. C2 ADJUSTABLE MOUNT**

Recommended mounting torque: 3 to 5 in. lbs.\*

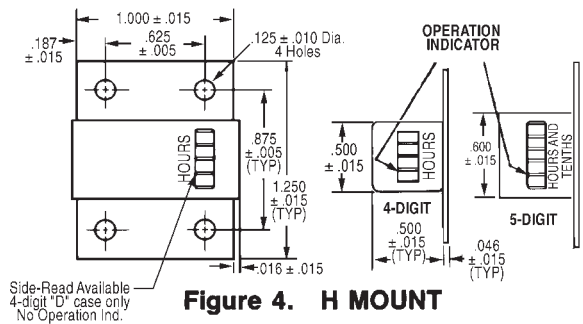
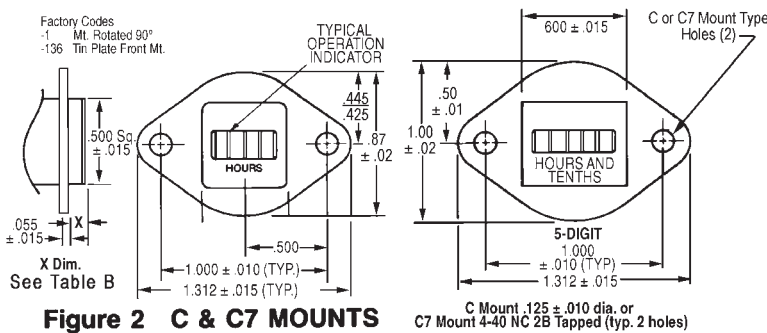

**Figure 4. H MOUNT**

Recommended mounting torque: 3 to 5 in. lbs.\*

Recommended Panel Cut-Out: .562" (9/16") X .625" (5/8"), 5 Digit

Factory Codes  
-1 Mt. Rotated 90°  
-136 Tin Plate Front Mt.



**Figure 2 C & C7 MOUNTS**

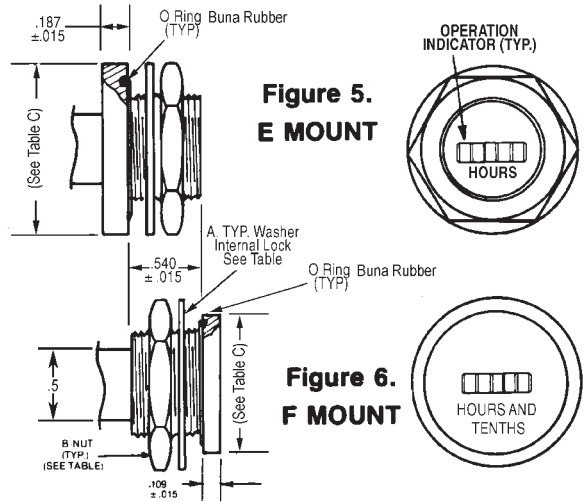

**Figure 5. E MOUNT**

Recommended mounting torque: 3 to 5 in. lbs.\*

Factory Codes  
-1 Mt. Rotated 90°  
-136 Tin Plate Front Mt.

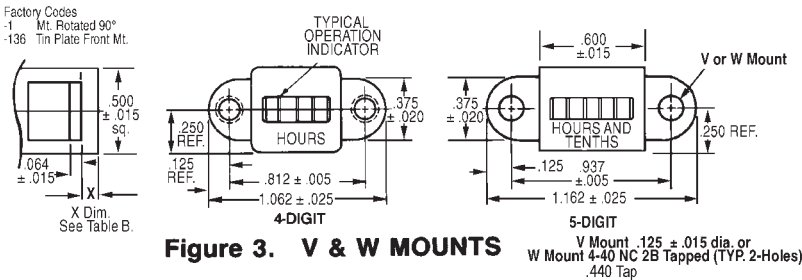

**Figure 3. V & W MOUNTS**

V Mount .125 ± .015 dia. or  
W Mount 4-40 NC 2B Tapped (TYP. 2-Holes)  
.440 Tap

	A Max. Dia.	B (Nut)	C ± .015 E Mount	F Mount
4 Digit	1.250	3/4"-32 UN	1.250	1.000
5 Digit	1.410	7/8"-20 UN		1.375

Recommended mounting torque, E & F mount  
4 digit..... 20 to 30 in. lbs.  
5 digit..... 60 to 70 in. lbs.  
6 digit..... 70 to 80 in. lbs.

## Round Cases & Mounts (for ETI only)

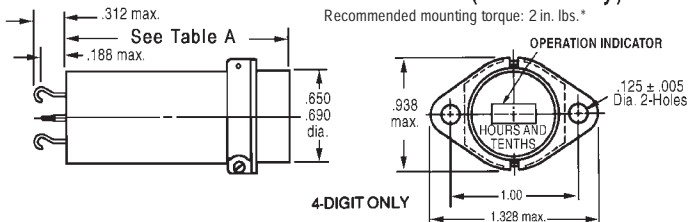

**Figure 7. C2 ADJUSTABLE MOUNT**

Factory Codes  
-1 Mt. Rotated 90°  
-136 Tin Plate Front Mt.

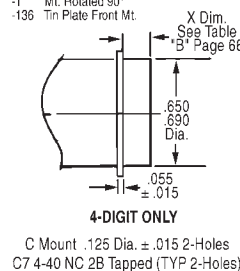

**Figure 8. C & C7 MOUNTS**

Recommended mounting torque: 3 to 5 in. lbs.\*

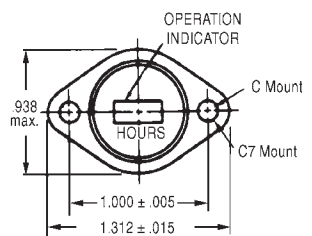

\*When mounting flanged units, it is recommended to distribute the mounting torque evenly across the mounting surface. Each mounting screw should be alternately tightened about one quarter to one half turn until the recommended torque is attained on each screw. The mounting surface should be flat to avoid exerting stress on the body of the unit.

This page consists of basic marketing information that is not defined as technical data under FAR Part 772.

# ELAPSED TIME INDICATORS AND EVENT COUNTERS



## Standard Cases & Mounts

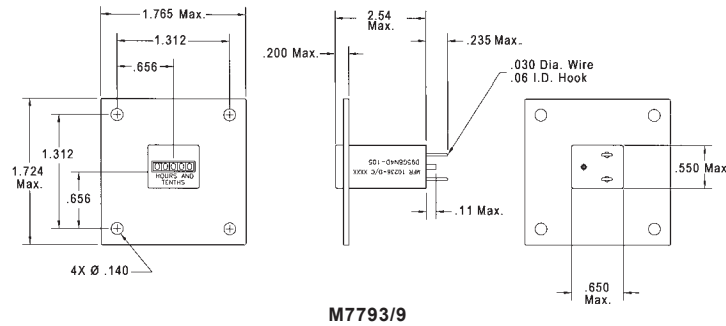
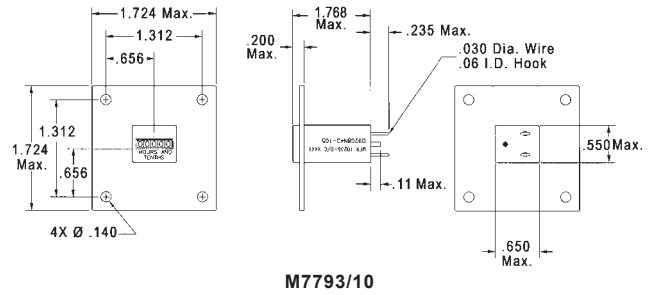
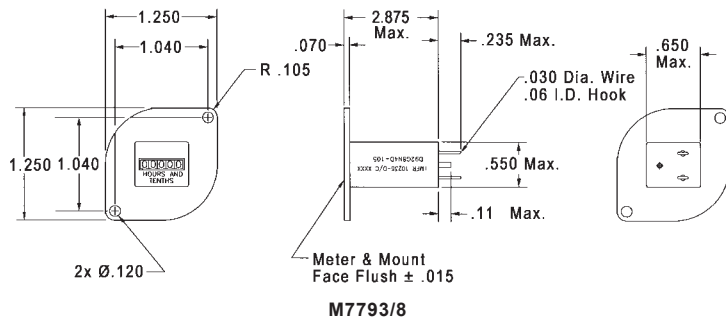

## Standard and Straight Pin Headers

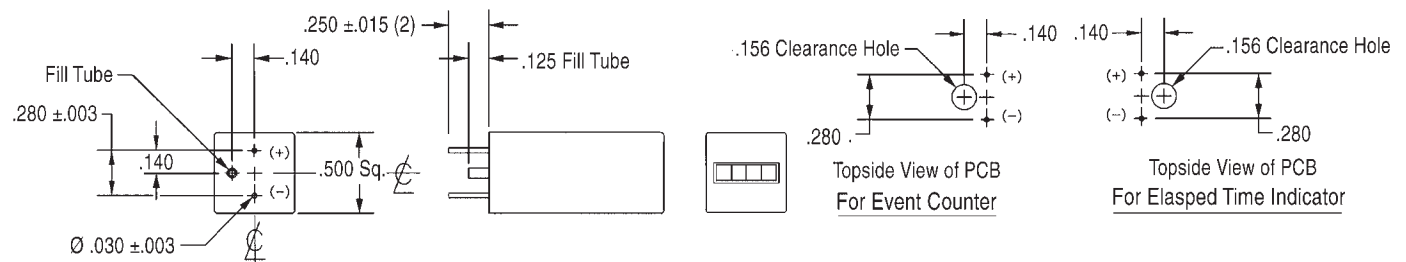
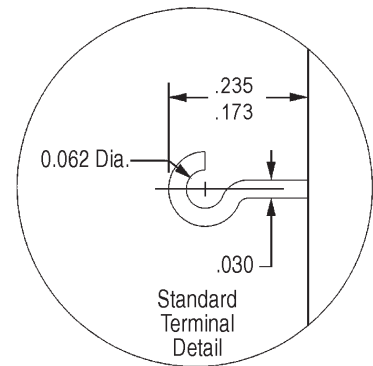
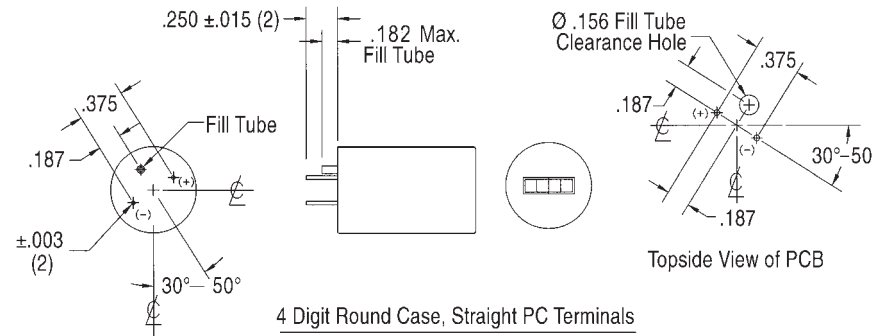

This page consists of basic marketing information that is not defined as technical data under EAR Part 772.

# ELAPSED TIME INDICATORS AND EVENT COUNTERS



ELAPSED TIME INDICATORS & EVENT COUNTERS

## 999A Series Enclosures

L-3 Electroynamics, Inc. offers customized enclosures to house a variety of Elapsed Time Indicators and Event Counters. The customized enclosures include the connectors, wire leads and mounting brackets, as required, for mounting into final assemblies. Refer to the Elapsed Time Indicator and Event Counter sections of the catalog for mechanical, electrical and environmental specifications.

DC series Elapsed Time Indicators meet or exceed requirements of MIL-M-7793-M7793/1, /2, /5 and MS21341 A & B.

AC series Elapsed Time Indicators meet or exceed applicable requirements of MIL-M-7793-M7793/3, /4, /6, /8, /9, /10 (if QPL'd), MS27650 and MS21651.

### ENCLOSURE EXAMPLES

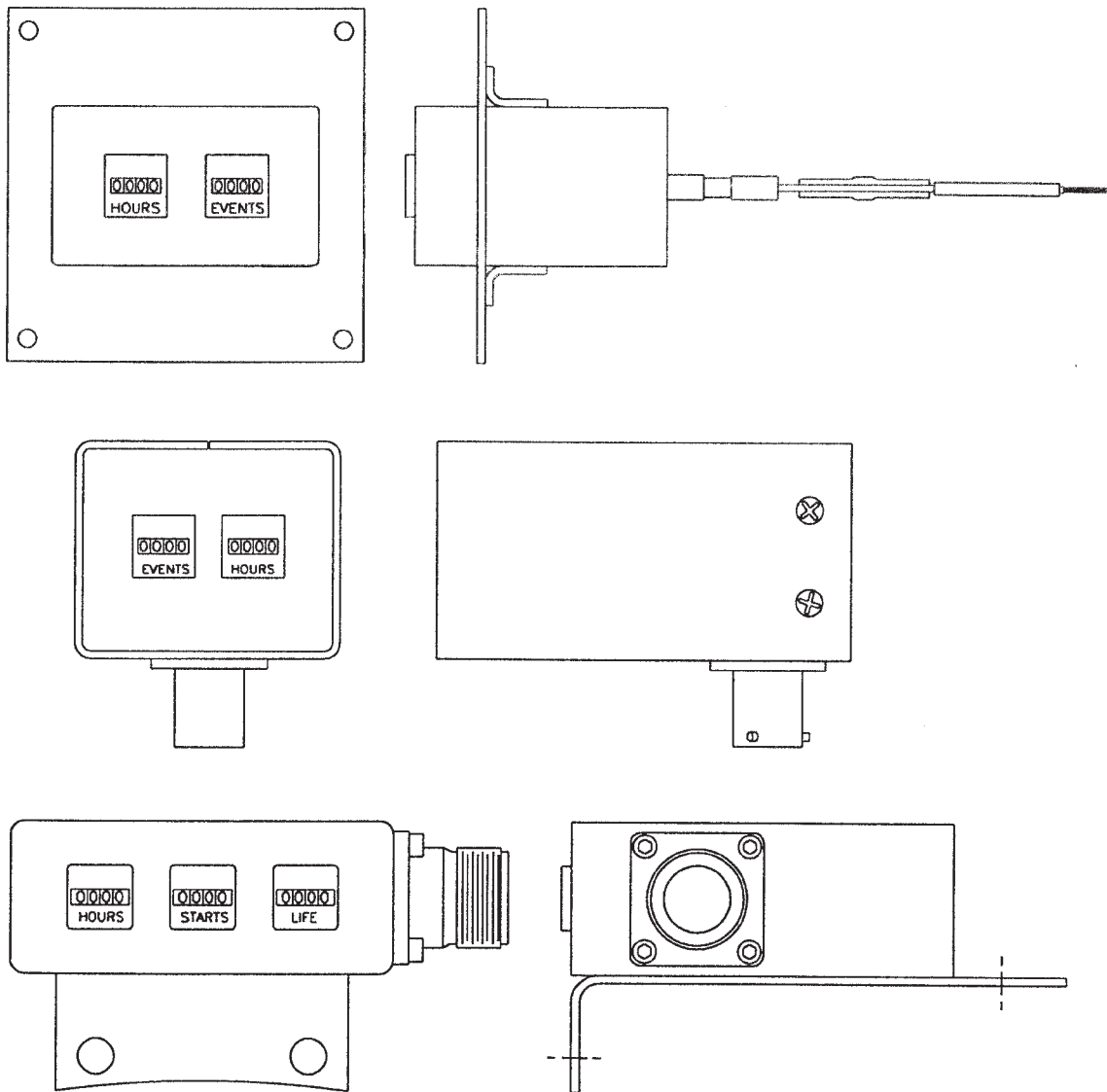

This page consists of basic marketing information that is not defined as technical data under FAR Part 772.

# MILITARY ELAPSED TIME INDICATOR GUIDE



**Table A Specifications**

Operating Voltage	Case Length Max. Inches	L-3 Electroynamics Model Number	Fig. No.	Military Number	
10-34 VDC	1.094 Short	D16C8C*-16	2	M7793/1-XXX	
		D16C8C2	1	M7793/1-001	
		D16C8A	—	M7793/1-002	
		D16C8C*-136	2	M7793/1-XXX	
		D16B8C2	7	M7793/2-001	
		D16B8A	—	M7793/2-002	
	2.062	Short	D16B8C*-136	8	M7793/2-XXX
			16B8C2	7	M7793/5-001
			16C8C2	1	M7793/5-002
			16C8C*-16	2	MS21341B-XX
2.062	Short	16C8C*-136	2	M7793/1-XXX	
100-130 VAC 50-70Hz	1.094 Short	D92C8C2	1	M7793/3-001	
		D92C8A	—	M7793/3-002	
		D92C8C*-136	2	M7793/3-XXX	
	Short	D92B8C2	7	M7793/4-001	
		D92B8A	—	M7793/4-002	
		D92B8C*-136	8	M7793/4-XXX	
100-130 VAC 380-420Hz	1.765	D95B8C2	7	M7793/6-001	
	1.094	D95C8C2	1	M7793/6-002	
	1.094 Short	C7*-16	2	MS27651-XXA	
		C7*-1-16	2	MS27651-XXB	
		D95C8 C*-16	2	MS27651-XXC	
		C*-1-16	2	MS27651-XXD	
		W*-16	3	MS27651-XXE	
		W*-1-16	3	MS27651-XXF	
V*-16	3	MS27651-XXG			
	3	MS27651-XXH			
15-40 VAC 380-420Hz	Replace <b>D95</b> above with <b>D25</b> Example: <b>D25C8CE-16 = MS27650-05C</b>		Replace <b>MS27651</b> above with <b>MS27650</b>		

**Notes:**

- All meter readouts are to 9999 Hours, maximum.
- See "Table B Mount Setback Data" to select desired "X" Dim. (\* in model no.) and corresponding military dash no. (xx & xxx).
- "-136" in model number denotes tin-plated mount face; "-16" in model number is same plus USAF testing; "-1" in model number is mount rotated 90°.

Qualified products purchased to the Military Part Number comply with the latest revision of the applicable Military Specification. Commercial, Non-Qualified, and EDI versions of Military Specification products are designed in accordance with the applicable Military Specification, but may not be tested and/or qualified per said Military Specification.

This page consists of basic marketing information that is not defined as technical data under EAR Part 772.

**Table B Mount Setback Data**

M7793/1 to /4 Dash No.	MS21341, 27650, 27651 Dash No.	Setback ± .015 In.	"X" Dim. Code
-003	-01	Flush	A
-004	-02	.031	B
-005	-03	.062	C
-006	-04	.094	D
-007	-05	.125	E
-008	-06	.156	F
-009	-07	.188	G
-010	-08	.219	H
-011	-09	.250	I
-012	-10	.281	J
-013	-11	.312	K
-014	-12	.344	L
-015	-13	.375	M
-016	-14	.406	N
-017	-15	.438	O
-018	-16	.469	P
-019	-17	.500	R
-020	-18	.531	S
-021	-19	.562	T
-022	-20	.594	T-8
-023	-21	.625	U
-024	-22	.656	U-8
-025	-23	.688	V
-026	-24	.719	V-8
-027	-25	.750	W
-028	-26	.781	W-8
		.813	X
		.875	Y
		.938	Z

**Table C Standard Options**

Code	Additional Standard Factory Options	AC/DC Meters	Events
1	Flange rotated 90° clockwise from standard	X	X
2	Flange rotated 180° clockwise from standard	X	X
3	Flange rotated 270° clockwise from standard	X	X
13	#4-40 self locking nylon clinch nut on backside of flange	X	X
14	#4-40 self locking stainless steel clinch nut on backside of flange	X	X
16	Front face of flange is pure tin plated and unit is tested an additional 25 hours per MS27650 / 27651 / 21341	X	
26	A flat is added to E mounts for D hole installation - .710" for 4 digit meter, .810" for 5 digit meter	X	X
28	"C/C7 type flanges, RFI gasket - Must be used with tin plated flange (-105, -136, -200) E & F mounts - RFI o-ring"	X	X
46	.150" long .030" diameter straight pins in place of hook terminals	X	X
47	.250" long .030" diameter straight pins in place of hook terminals	X	X
75	RFI conductive glass window	X	X
105	Rear face of flange is pure tin plated	X	X
136	Front face of flange is pure tin plated	X	X
200	Front & rear face of flange is pure tin plated	X	X
237	Entire unit except terminals is painted and unit is tested an additional 25 hours per MS27650 / 27651 / 21341	X	
493	A flat is added to F mounts for D hole installation - .710" for 4 digit, .810" for 5 digit	X	X

ELAPSED TIME INDICATORS & EVENT COUNTERS

# MIL SERIES MILITARY CROSS REFERENCE GUIDE



ELAPSED TIME INDICATORS & EVENT COUNTERS

If ordering a MIL part, use MIL Spec & EDI Number.  
If ordering a Commercial part, use the Commercial Number.

MIL SPEC & EDI NUMBER M7793/1	COMMERCIAL NUMBER 4 Digit Short Square 10-34 VDC	MIL SPEC & EDI NUMBER M7793/2	COMMERCIAL NUMBER 4 Digit Short Round 10-34 VDC	MIL SPEC & EDI NUMBER M7793/3	COMMERCIAL NUMBER 4 Digit Short Square 100-130 VAC/50-70Hz	MIL SPEC & EDI NUMBER M7793/4	COMMERCIAL NUMBER 4 Digit Short Round 100-130 VAC/50-70Hz
M7793/1-001	D16C8C2	M7793/2-001	D16B8C2	M7793/3-001	D92C8C2	M7793/4-001	D92B8C2
M7793/1-002	D16C8A	M7793/2-002	D16B8A	M7793/3-002	D92C8A	M7793/4-002	D92B8A
M7793/1-003	D16C8CA-136	M7793/2-003	D16B8CA-136	M7793/3-003	D92C8CA-136	M7793/4-003	D92B8CA-136
M7793/1-004	D16C8CB-136	M7793/2-004	D16B8CB-136	M7793/3-004	D92C8CB-136	M7793/4-004	D92B8CB-136
M7793/1-005	D16C8CC-136	M7793/2-005	D16B8CC-136	M7793/3-005	D92C8CC-136	M7793/4-005	D92B8CC-136
M7793/1-006	D16C8CD-136	M7793/2-006	D16B8CD-136	M7793/3-006	D92C8CD-136	M7793/4-006	D92B8CD-136
M7793/1-007	D16C8CE-136	M7793/2-007	D16B8CE-136	M7793/3-007	D92C8CE-136	M7793/4-007	D92B8CE-136
M7793/1-008	D16C8CF-136	M7793/2-008	D16B8CF-136	M7793/3-008	D92C8CF-136	M7793/4-008	D92B8CF-136
M7793/1-009	D16C8CG-136	M7793/2-009	D16B8CG-136	M7793/3-009	D92C8CG-136	M7793/4-009	D92B8CG-136
M7793/1-010	D16C8CH-136	M7793/2-010	D16B8CH-136	M7793/3-010	D92C8CH-136	M7793/4-010	D92B8CH-136
M7793/1-011	D16C8CI-136	M7793/2-011	D16B8CI-136	M7793/3-011	D92C8CI-136	M7793/4-011	D92B8CI-136
M7793/1-012	D16C8CJ-136	M7793/2-012	D16B8CJ-136	M7793/3-012	D92C8CJ-136	M7793/4-012	D92B8CJ-136
M7793/1-013	D16C8CK-136	M7793/2-013	D16B8CK-136	M7793/3-013	D92C8CK-136	M7793/4-013	D92B8CK-136
M7793/1-014	D16C8CL-136	M7793/2-014	D16B8CL-136	M7793/3-014	D92C8CL-136	M7793/4-014	D92B8CL-136
M7793/1-015	D16C8CM-136	M7793/2-015	D16B8CM-136	M7793/3-015	D92C8CM-136	M7793/4-015	D92B8CM-136
M7793/1-016	D16C8CN-136	M7793/2-016	D16B8CN-136	M7793/3-016	D92C8CN-136	M7793/4-016	D92B8CN-136
M7793/1-017	D16C8CO-136	M7793/2-017	D16B8CO-136	M7793/3-017	D92C8CO-136	M7793/4-017	D92B8CO-136
M7793/1-018	D16C8CP-136	M7793/2-018	D16B8CP-136	M7793/3-018	D92C8CP-136	M7793/4-018	D92B8CP-136
M7793/1-019	D16C8CR-136	M7793/2-019	D16B8CR-136	M7793/3-019	D92C8CR-136	M7793/4-019	D92B8CR-136
M7793/1-020	D16C8CS-136	M7793/2-020	D16B8CS-136	M7793/3-020	D92C8CS-136	M7793/4-020	D92B8CS-136
M7793/1-021	D16C8CT-136	M7793/2-021	D16B8CT-136	M7793/3-021	D92C8CT-136	M7793/4-021	D92B8CT-136
M7793/1-022	D16C8CT-8-136	M7793/2-022	D16B8CT-8-136	M7793/3-022	D92C8CT-8-136	M7793/4-022	D92B8CT-8-136
M7793/1-023	D16C8CU-136	M7793/2-023	D16B8CU-136	M7793/3-023	D92C8CU-136	M7793/4-023	D92B8CU-136
M7793/1-024	D16C8CU-8-136	M7793/2-024	D16B8CU-8-136	M7793/3-024	D92C8CU-8-136	M7793/4-024	D92B8CU-8-136
M7793/1-025	D16C8CV-136	M7793/2-025	D16B8CV-136	M7793/3-025	D92C8CV-136	M7793/4-025	D92B8CV-136
M7793/1-026	D16C8CV-8-136	M7793/2-026	D16B8CV-8-136	M7793/3-026	D92C8CV-8-136	M7793/4-026	D92B8CV-8-136
M7793/1-027	D16C8CW-136	M7793/2-027	D16B8CW-136	M7793/3-027	D92C8CW-136	M7793/4-027	D92B8CW-136
M7793/1-028	D16C8CW-8-136	M7793/2-028	D16B8CW-8-136	M7793/3-028	D92C8CW-8-136	M7793/4-028	D92B8CW-8-136

MIL SPEC & EDI NUMBER M7793/5	COMMERCIAL NUMBER 4 Digit Round & Square 10-34 VDC	MIL SPEC & EDI NUMBER M7793/6	COMMERCIAL NUMBER 4 Digit Round & Square 100-130 VAC/380-420Hz	MIL SPEC & EDI NUMBER MS21341A	COMMERCIAL NUMBER ①	MIL SPEC & EDI NUMBER MS21341B	COMMERCIAL NUMBER ②
M7793/5-001	16B8C2(Rnd)	M7793/6-001	D95B8C2(Rnd)	MS21341A-01	D16C8CA-16	MS21341B-01	16C8CA-16
M7793/5-002	16C8C2(Sqr)	M7793/6-002	D95C8C2(Sqr)	MS21341A-02	D16C8CB-16	MS21341B-02	16C8CB-16
				MS21341A-03	D16C8CC-16	MS21341B-03	16C8CC-16
				MS21341A-04	D16C8CD-16	MS21341B-04	16C8CD-16
				MS21341A-05	D16C8CE-16	MS21341B-05	16C8CE-16
				MS21341A-06	D16C8CF-16	MS21341B-06	16C8CF-16
				MS21341A-07	D16C8CG-16	MS21341B-07	16C8CG-16
				MS21341A-08	D16C8CH-16	MS21341B-08	16C8CH-16
				MS21341A-09	D16C8CI-16	MS21341B-09	16C8CI-16
				MS21341A-10	D16C8CJ-16	MS21341B-10	16C8CJ-16
				MS21341A-11	D16C8CK-16	MS21341B-11	16C8CK-16
				MS21341A-12	D16C8CL-16	MS21341B-12	16C8CL-16
				MS21341A-13	D16C8CM-16	MS21341B-13	16C8CM-16
				MS21341A-14	D16C8CN-16	MS21341B-14	16C8CN-16
				MS21341A-15	D16C8CO-16	MS21341B-15	16C8CO-16
				MS21341A-16	D16C8CP-16	MS21341B-16	16C8CP-16
				MS21341A-17	D16C8CR-16	MS21341B-17	16C8CR-16
				MS21341A-18	D16C8CS-16	MS21341B-18	16C8CS-16
				MS21341A-19	D16C8CT-16	MS21341B-19	16C8CT-16
				MS21341A-20	D16C8CT-8-16	MS21341B-20	16C8CT-8-16
				MS21341A-21	D168CU-16	MS21341B-21	16C8CU-16
				MS21341A-22	D16C8CU-8-16	MS21341B-22	16C8CU-8-16
				MS21341A-23	D16C8CV-16	MS21341B-23	16C8CV-16
				MS21341A-24	D16C8CV-8-16	MS21341B-24	16C8CV-8-16
				MS21341A-25	D16C8CW-16	MS21341B-25	16C8CW-16
				MS21341A-26	D16C8CW-8-16	MS21341B-26	16C8CW-8-16

Notes: ① 4-Digit Short Square 10-34 VDC    ③ 4-Digit Short Square 23-29 VAC/380-420 Hz  
② 4-Digit Long Square 10-34 VDC    ④ 4-Digit Short Square 100-130 VAC/380-420 Hz

Qualified products purchased to the Military Part Number comply with the latest revision of the applicable Military Specification. Commercial, Non-Qualified, and EDI versions of Military Specification products are designed in accordance with the applicable Military Specification, but may not be tested and/or qualified per said Military Specification.

This page consists of basic marketing information that is not defined as technical data under FAR Part 772.

# MIL SERIES MILITARY CROSS REFERENCE GUIDE



If ordering a MIL part, use MIL Spec & EDI Number.  
If ordering a Commercial part, use the Commercial Number.

MIL SPEC & EDI NUMBER	COMMERCIAL NUMBER ③	MIL SPEC & EDI NUMBER	COMMERCIAL NUMBER ③	MIL SPEC & EDI NUMBER	COMMERCIAL NUMBER ③	MIL SPEC & EDI NUMBER	COMMERCIAL NUMBER ③
MS27650-01A	D25C8C7A-16	MS27650-01B	D25C8C7A-1-16	MS27650-01E	D25C8WA-16	MS27650-01F	D25C8WA-1-16
MS27650-02A	D25C8C7B-16	MS27650-02B	D25C8C7B-1-16	MS27650-02E	D25C8WB-16	MS27650-02F	D25C8WB-1-16
MS27650-03A	D25C8C7C-16	MS27650-03B	D25C8C7C-1-16	MS27650-03E	D25C8WC-16	MS27650-03F	D25C8WC-1-16
MS27650-04A	D25C8C7D-16	MS27650-04B	D25C8C7D-1-16	MS27650-04E	D25C8WD-16	MS27650-04F	D25C8WD-1-16
MS27650-05A	D25C8C7E-16	MS27650-05B	D25C8C7E-1-16	MS27650-05E	D25C8WE-16	MS27650-05F	D25C8WE-1-16
MS27650-06A	D25C8C7F-16	MS27650-06B	D25C8C7F-1-16	MS27650-06E	D25C8WF-16	MS27650-06F	D25C8WF-1-16
MS27650-07A	D25C8C7G-16	MS27650-07B	D25C8C7G-1-16	MS27650-07E	D25C8WG-16	MS27650-07F	D25C8WG-1-16
MS27650-08A	D25C8C7H-16	MS27650-08B	D25C8C7H-1-16	MS27650-08E	D25C8WH-16	MS27650-08F	D25C8WH-1-16
MS27650-09A	D25C8C7I-16	MS27650-09B	D25C8C7I-1-16	MS27650-09E	D25C8WI-16	MS27650-09F	D25C8WI-1-16
MS27650-10A	D25C8C7J-16	MS27650-10B	D25C8C7J-1-16	MS27650-10E	D25C8WJ-16	MS27650-10F	D25C8WJ-1-16
MS27650-11A	D25C8C7K-16	MS27650-11B	D25C8C7K-1-16	MS27650-11E	D25C8WK-16	MS27650-11F	D25C8WK-1-16
MS27650-12A	D25C8C7L-16	MS27650-12B	D25C8C7L-1-16	MS27650-12E	D25C8WL-16	MS27650-12F	D25C8WL-1-16
MS27650-13A	D25C8C7M-16	MS27650-13B	D25C8C7M-1-16	MS27650-13E	D25C8WM-16	MS27650-13F	D25C8WM-1-16
MS27650-14A	D25C8C7N-16	MS27650-14B	D25C8C7N-1-16	MS27650-14E	D25C8WN-16	MS27650-14F	D25C8WN-1-16
MS27650-15A	D25C8C7O-16	MS27650-15B	D25C8C7O-1-16	MS27650-15E	D25C8WO-16	MS27650-15F	D25C8WO-1-16
MS27650-16A	D25C8C7P-16	MS27650-16B	D25C8C7P-1-16	MS27650-16E	D25C8WP-16	MS27650-16F	D25C8WP-1-16
MS27650-17A	D25C8C7R-16	MS27650-17B	D25C8C7R-1-16	MS27650-17E	D25C8WR-16	MS27650-17F	D25C8WR-1-16
MS27650-18A	D25C8C7S-16	MS27650-18B	D25C8C7S-1-16	MS27650-18E	D25C8WS-16	MS27650-18F	D25C8WS-1-16
MS27650-19A	D25C8C7T-16	MS27650-19B	D25C8C7T-1-16	MS27650-19E	D25C8WT-16	MS27650-19F	D25C8WT-1-16
MS27650-20A	D25C8C7T-8-16	MS27650-20B	D25C8C7T-8-1-16	MS27650-20E	D25C8WT-8-16	MS27650-20F	D25C8WT-8-16
MS27650-21A	D25C8C7U-16	MS27650-21B	D25C8C7U-1-16	MS27650-21E	D25C8WU-16	MS27650-21F	D25C8WU-1-16
MS27650-22A	D25C8C7U-8-16	MS27650-22B	D25C8C7U-8-1-16	MS27650-22E	D25C8WU-8-16	MS27650-22F	D25C8WU-8-1-16
MS27650-23A	D25C8C7V-16	MS27650-23B	D25C8C7V-1-16	MS27650-23E	D25C8WV-16	MS27650-23F	D25C8WV-1-16
MS27650-24A	D25C8C7V-8-16	MS27650-24B	D25C8C7V-8-1-16	MS27650-24E	D25C8WV-8-16	MS27650-24F	D25C8WV-8-1-16
MS27650-25A	D25C8C7W-16	MS27650-25B	D25C8C7W-1-16	MS27650-25E	D25C8WW-16	MS27650-25F	D25C8WW-1-16
MS27650-26A	D25C8C7W-8-16	MS27650-26B	D25C8C7W-8-1-16	MS27650-26E	D25C8WW-8-16	MS27650-26F	D25C8WW-8-1-16

MIL SPEC & EDI NUMBER	COMMERCIAL NUMBER ③	MIL SPEC & EDI NUMBER	COMMERCIAL NUMBER ③	MIL SPEC & EDI NUMBER	COMMERCIAL NUMBER ③	MIL SPEC & EDI NUMBER	COMMERCIAL NUMBER ③
MS27650-01C	D25C8CA-16	MS27650-01D	D25C8CA-1-16	MS27650-01G	D25C8VA-16	MS27650-01H	D25C8VA-1-16
MS27650-02C	D25C8CB-16	MS27650-02D	D25C8CB-1-16	MS27650-02G	D25C8VB-16	MS27650-02H	D25C8VB-1-16
MS27650-03C	D25C8CC-16	MS27650-03D	D25C8CC-1-16	MS27650-03G	D25C8VC-16	MS27650-03H	D25C8VC-1-16
MS27650-04C	D25C8CD-16	MS27650-04D	D25C8CD-1-16	MS27650-04G	D25C8VD-16	MS27650-04H	D25C8VD-1-16
MS27650-05C	D25C8CE-16	MS27650-05D	D25C8CE-1-16	MS27650-05G	D25C8VE-16	MS27650-05H	D25C8VE-1-16
MS27650-06C	D25C8CF-16	MS27650-06D	D25C8CF-1-16	MS27650-06G	D25C8VF-16	MS27650-06H	D25C8VF-1-16
MS27650-07C	D25C8CG-16	MS27650-07D	D25C8CG-1-16	MS27650-07G	D25C8VG-16	MS27650-07H	D25C8VG-1-16
MS27650-08C	D25C8CH-16	MS27650-08D	D25C8CH-1-16	MS27650-08G	D25C8VH-16	MS27650-08H	D25C8VH-1-16
MS27650-09C	D25C8CI-16	MS27650-09D	D25C8CI-1-16	MS27650-09G	D25C8VI-16	MS27650-09H	D25C8VI-1-16
MS27650-10C	D25C8CJ-16	MS27650-10D	D25C8CJ-1-16	MS27650-10G	D25C8VJ-16	MS27650-10H	D25C8VJ-1-16
MS27650-11C	D25C8CK-16	MS27650-11D	D25C8CK-1-16	MS27650-11G	D25C8VK-16	MS27650-11H	D25C8VK-1-16
MS27650-12C	D25C8CL-16	MS27650-12D	D25C8CL-1-16	MS27650-12G	D25C8VL-16	MS27650-12H	D25C8VL-1-16
MS27650-13C	D25C8CM-16	MS27650-13D	D25C8CM-1-16	MS27650-13G	D25C8VM-16	MS27650-13H	D25C8VM-1-16
MS27650-14C	D25C8CN-16	MS27650-14D	D25C8CN-1-16	MS27650-14G	D25C8VN-16	MS27650-14H	D25C8VN-1-16
MS27650-15C	D25C8CO-16	MS27650-15D	D25C8CO-1-16	MS27650-15G	D25C8VO-16	MS27650-15H	D25C8VO-1-16
MS27650-16C	D25C8CP-16	MS27650-16D	D25C8CP-1-16	MS27650-16G	D25C8VP-16	MS27650-16H	D25C8VP-1-16
MS27650-17C	D25C8CR-16	MS27650-17D	D25C8CR-1-16	MS27650-17G	D25C8VR-16	MS27650-17H	D25C8VR-1-16
MS27650-18C	D25C8CS-16	MS27650-18D	D25C8CS-1-16	MS27650-18G	D25C8VS-16	MS27650-18H	D25C8VS-1-16
MS27650-19C	D25C8CT-16	MS27650-19D	D25C8CT-1-16	MS27650-19G	D25C8VT-16	MS27650-19H	D25C8VT-1-16
MS27650-20C	D25C8CT-8-16	MS27650-20D	D25C8CT-8-1-16	MS27650-20G	D25C8VT-8-16	MS27650-20H	D25C8VT-8-1-16
MS27650-21C	D25C8CU-16	MS27650-21D	D25C8CU-1-16	MS27650-21G	D25C8VU-16	MS27650-21H	D25C8VU-1-16
MS27650-22C	D25C8CU-8-16	MS27650-22D	D25C8CU-8-1-16	MS27650-22G	D25C8VU-8-16	MS27650-22H	D25C8VU-8-1-16
MS27650-23C	D25C8CV-16	MS27650-23D	D25C8CV-1-16	MS27650-23G	D25C8VV-16	MS27650-23H	D25C8VV-1-16
MS27650-24C	D25C8CV-8-16	MS27650-24D	D25C8CV-8-1-16	MS27650-24G	D25C8VV-8-16	MS27650-24H	D25C8VV-8-1-16
MS27650-25C	D25C8CW-16	MS27650-25D	D25C8CW-1-16	MS27650-25G	D25C8VW-16	MS27650-25H	D25C8VW-1-16
MS27650-26C	D25C8CW-8-16	MS27650-26D	D25C8CW-8-1-16	MS27650-26G	D25C8VW-8-16	MS27650-26H	D25C8VW-8-1-16

Notes: ① 4-Digit Short Square 10-34 VDC    ③ 4-Digit Short Square 23-29 VAC/380-420 Hz  
② 4-Digit Long Square 10-34 VDC    ④ 4-Digit Short Square 100-130 VAC/380-420 Hz

Qualified products purchased to the Military Part Number comply with the latest revision of the applicable Military Specification. Commercial, Non-Qualified, and EDI versions of Military Specification products are designed in accordance with the applicable Military Specification, but may not be tested and/or qualified per said Military Specification.

This page consists of basic marketing information that is not defined as technical data under EAR Part 772.

ELAPSED TIME INDICATORS & EVENT COUNTERS

# MIL SERIES MILITARY CROSS REFERENCE GUIDE



ELAPSED TIME INDICATORS & EVENT COUNTERS

If ordering a MIL part, use MIL Spec & EDI Number.  
If ordering a Commercial part, use the Commercial Number.

MIL SPEC & EDI NUMBER	COMMERCIAL NUMBER ④	MIL SPEC & EDI NUMBER	COMMERCIAL NUMBER ④	MIL SPEC & EDI NUMBER	COMMERCIAL NUMBER ④	MIL SPEC & EDI NUMBER	COMMERCIAL NUMBER ④
MS27651-01A	D95C8C7A-16	MS27651-01B	D95C8C7A-1-16	MS27651-01E	D95C8WA-16	MS27651-01F	D95C8WA-1-16
MS27651-02A	D95C8C7B-16	MS27651-02B	D95C8C7B-1-16	MS27651-02E	D95C8WB-16	MS27651-02F	D95C8WB-1-16
MS27651-03A	D95C8C7C-16	MS27651-03B	D95C8C7C-1-16	MS27651-03E	D95C8WC-16	MS27651-03F	D95C8WC-1-16
MS27651-04A	D95C8C7D-16	MS27651-04B	D95C8C7D-1-16	MS27651-04E	D95C8WD-16	MS27651-04F	D95C8WD-1-16
MS27651-05A	D95C8C7E-16	MS27651-05B	D95C8C7E-1-16	MS27651-05E	D95C8WE-16	MS27651-05F	D95C8WE-1-16
MS27651-06A	D95C8C7F-16	MS27651-06B	D95C8C7F-1-16	MS27651-06E	D95C8WF-16	MS27651-06F	D95C8WF-1-16
MS27651-07A	D95C8C7G-16	MS27651-07B	D95C8C7G-1-16	MS27651-07E	D95C8WG-16	MS27651-07F	D95C8WG-1-16
MS27651-08A	D95C8C7H-16	MS27651-08B	D95C8C7H-1-16	MS27651-08E	D95C8WH-16	MS27651-08F	D95C8WH-1-16
MS27651-09A	D95C8C7I-16	MS27651-09B	D95C8C7I-1-16	MS27651-09E	D95C8WI-16	MS27651-09F	D95C8WI-1-16
MS27651-10A	D95C8C7J-16	MS27651-10B	D95C8C7J-1-16	MS27651-10E	D95C8WJ-16	MS27651-10F	D95C8WJ-1-16
MS27651-11A	D95C8C7K-16	MS27651-11B	D95C8C7K-1-16	MS27651-11E	D95C8WK-16	MS27651-11F	D95C8WK-1-16
MS27651-12A	D95C8C7L-16	MS27651-12B	D95C8C7L-1-16	MS27651-12E	D95C8WL-16	MS27651-12F	D95C8WL-1-16
MS27651-13A	D95C8C7M-16	MS27651-13B	D95C8C7M-1-16	MS27651-13E	D95C8WM-16	MS27651-13F	D95C8WM-1-16
MS27651-14A	D95C8C7N-16	MS27651-14B	D95C8C7N-1-16	MS27651-14E	D95C8WN-16	MS27651-14F	D95C8WN-1-16
MS27651-15A	D95C8C7O-16	MS27651-15B	D95C8C7O-1-16	MS27651-15E	D95C8WO-16	MS27651-15F	D95C8WO-1-16
MS27651-16A	D95C8C7P-16	MS27651-16B	D95C8C7P-1-16	MS27651-16E	D95C8WP-16	MS27651-16F	D95C8WP-1-16
MS27651-17A	D95C8C7Q-16	MS27651-17B	D95C8C7Q-1-16	MS27651-17E	D95C8WR-16	MS27651-17F	D95C8WR-1-16
MS27651-18A	D95C8C7S-16	MS27651-18B	D95C8C7S-1-16	MS27651-18E	D95C8WS-16	MS27651-18F	D95C8WS-1-16
MS27651-19A	D95C8C7T-16	MS27651-19B	D95C8C7T-1-16	MS27651-19E	D95C8WT-16	MS27651-19F	D95C8WT-1-16
MS27651-20A	D95C8C7T-8-16	MS27651-20B	D95C8C7T-8-1-16	MS27651-20E	D95C8WT-8-16	MS27651-20F	D95C8WT-8-16
MS27651-21A	D95C8C7U-16	MS27651-21B	D95C8C7U-1-16	MS27651-21E	D95C8WU-16	MS27651-21F	D95C8WU-1-16
MS27651-22A	D95C8C7U-8-16	MS27651-22B	D95C8C7U-8-1-16	MS27651-22E	D95C8WU-8-16	MS27651-22F	D95C8WU-8-1-16
MS27651-23A	D95C8C7V-16	MS27651-23B	D95C8C7V-1-16	MS27651-23E	D95C8WV-16	MS27651-23F	D95C8WV-1-16
MS27651-24A	D95C8C7V-8-16	MS27651-24B	D95C8C7V-8-1-16	MS27651-24E	D95C8WV-8-16	MS27651-24F	D95C8WV-8-1-16
MS27651-25A	D95C8C7W-16	MS27651-25B	D95C8C7W-1-16	MS27651-25E	D95C8WW-16	MS27651-25F	D95C8WW-1-16
MS27651-26A	D95C8C7W-8-16	MS27651-26B	D95C8C7W-8-1-16	MS27651-26E	D95C8WW-8-16	MS27651-26F	D95C8WW-8-1-16

MIL SPEC & EDI NUMBER	COMMERCIAL NUMBER ④	MIL SPEC & EDI NUMBER	COMMERCIAL NUMBER ④	MIL SPEC & EDI NUMBER	COMMERCIAL NUMBER ④	MIL SPEC & EDI NUMBER	COMMERCIAL NUMBER ④
MS27651-01C	D95C8CA-16	MS27651-01D	D95C8CA-1-16	MS27651-01G	D95C8VA-16	MS27651-01H	D95C8VA-1-16
MS27651-02C	D95C8CB-16	MS27651-02D	D95C8CB-1-16	MS27651-02G	D95C8VB-16	MS27651-02H	D95C8VB-1-16
MS27651-03C	D95C8CC-16	MS27651-03D	D95C8CC-1-16	MS27651-03G	D95C8VC-16	MS27651-03H	D95C8VC-1-16
MS27651-04C	D95C8CD-16	MS27651-04D	D95C8CD-1-16	MS27651-04G	D95C8VD-16	MS27651-04H	D95C8VD-1-16
MS27651-05C	D95C8CE-16	MS27651-05D	D95C8CE-1-16	MS27651-05G	D95C8VE-16	MS27651-05H	D95C8VE-1-16
MS27651-06C	D95C8CF-16	MS27651-06D	D95C8CF-1-16	MS27651-06G	D95C8VF-16	MS27651-06H	D95C8VF-1-16
MS27651-07C	D95C8CG-16	MS27651-07D	D95C8CG-1-16	MS27651-07G	D95C8VG-16	MS27651-07H	D95C8VG-1-16
MS27651-08C	D95C8CH-16	MS27651-08D	D95C8CH-1-16	MS27651-08G	D95C8VH-16	MS27651-08H	D95C8VH-1-16
MS27651-09C	D95C8CI-16	MS27651-09D	D95C8CI-1-16	MS27651-09G	D95C8VI-16	MS27651-09H	D95C8VI-1-16
MS27651-10C	D95C8CJ-16	MS27651-10D	D95C8CJ-1-16	MS27651-10G	D95C8VJ-16	MS27651-10H	D95C8VJ-1-16
MS27651-11C	D95C8CK-16	MS27651-11D	D95C8CK-1-16	MS27651-11G	D95C8VK-16	MS27651-11H	D95C8VK-1-16
MS27651-12C	D95C8CL-16	MS27651-12D	D95C8CL-1-16	MS27651-12G	D95C8VL-16	MS27651-12H	D95C8VL-1-16
MS27651-13C	D95C8CM-16	MS27651-13D	D95C8CM-1-16	MS27651-13G	D95C8VM-16	MS27651-13H	D95C8VM-1-16
MS27651-14C	D95C8CN-16	MS27651-14D	D95C8CN-1-16	MS27651-14G	D95C8VN-16	MS27651-14H	D95C8VN-1-16
MS27651-15C	D95C8CO-16	MS27651-15D	D95C8CO-1-16	MS27651-15G	D95C8VO-16	MS27651-15H	D95C8VO-1-16
MS27651-16C	D95C8CP-16	MS27651-16D	D95C8CP-1-16	MS27651-16G	D95C8VP-16	MS27651-16H	D95C8VP-1-16
MS27651-17C	D95C8CR-16	MS27651-17D	D95C8CR-1-16	MS27651-17G	D95C8VR-16	MS27651-17H	D95C8VR-1-16
MS27651-18C	D95C8CS-16	MS27651-18D	D95C8CS-1-16	MS27651-18G	D95C8VS-16	MS27651-18H	D95C8VS-1-16
MS27651-19C	D95C8CT-16	MS27651-19D	D95C8CT-1-16	MS27651-19G	D95C8VT-16	MS27651-19H	D95C8VT-1-16
MS27651-20C	D95C8CT-8-16	MS27651-20D	D95C8CT-8-1-16	MS27651-20G	D95C8VT-8-16	MS27651-20H	D95C8VT-8-1-16
MS27651-21C	D95C8CU-16	MS27651-21D	D95C8CU-1-16	MS27651-21G	D95C8VU-16	MS27651-21H	D95C8VU-1-16
MS27651-22C	D95C8CU-8-16	MS27651-22D	D95C8CU-8-1-16	MS27651-22G	D95C8VU-8-16	MS27651-22H	D95C8VU-8-1-16
MS27651-23C	D95C8CV-16	MS27651-23D	D95C8CV-1-16	MS27651-23G	D95C8VV-16	MS27651-23H	D95C8VV-1-16
MS27651-24C	D95C8CV-8-16	MS27651-24D	D95C8CV-8-1-16	MS27651-24G	D95C8VV-8-16	MS27651-24H	D95C8VV-8-1-16
MS27651-25C	D95C8CW-16	MS27651-25D	D95C8CW-1-16	MS27651-25G	D95C8VW-16	MS27651-25H	D95C8VW-1-16
MS27651-26C	D95C8CW-8-16	MS27651-26D	D95C8CW-8-1-16	MS27651-26G	D95C8VW-8-16	MS27651-26H	D95C8VW-8-1-16

**Notes:** ① 4-Digit Short Square 10-34 VDC    ③ 4-Digit Short Square 23-29 VAC/380-420 Hz  
② 4-Digit Long Square 10-34 VDC    ④ 4-Digit Short Square 100-130 VAC/380-420 Hz

Qualified products purchased to the Military Part Number comply with the latest revision of the applicable Military Specification. Commercial, Non-Qualified, and EDI versions of Military Specification products are designed in accordance with the applicable Military Specification, but may not be tested and/or qualified per said Military Specification.

This page consists of basic marketing information that is not defined as technical data under FAR Part 772.



# ELAPSED TIME INDICATORS & EVENT COUNTERS SOLID-STATE, PC BOARD MOUNT



ELAPSED TIME INDICATORS & EVENT COUNTERS

## Digital Series Models DDS100 & DDS101

### Elapsed Time Indicator Model

DDS100 Solid-State Elapsed Time Indicators have been developed to meet the most difficult requirements of many military and aerospace applications. In one PCB mount package, the DDS100 provides highly reliable means of monitoring the system. All connections are made via printed wiring and the output brought to a data collection point for system reading or to a single dedicated connector.

Elapsed time can be read from the meter by mating the printed wiring board connections with the M7793/12-1 reader's connector and operating the reader. Time range is 99999.99 hours.

### Event Counter Model

The DDS101 Solid-State Event Counter records counts when the unit receives power for greater than 5 seconds. Power-on times of less than 4 seconds will not cause the counter to increment, allowing the count to be read without affecting the results. The count range is 9,999,999.

All connections, data collection, and the display of counts are made in the same manner as the DDS100 Elapsed Time Indicator. The DDS101 Event Counter meets the requirements of M7793 and the same environmental, mechanical, and electrical specifications as the DDS100.

### FEATURES

- Monitors your system usage
- PCB mount
- Non-volatile memory
- Elapsed Time Indicator model meets MIL-M-7793/13
- MIL-M-7793/13 qualified model is also available

### MECHANICAL SPECIFICATIONS

**Case Dimensions:** 1.1" long x .450" wide x .275" high

**Package Size:** I/A/W meets M7793/13

**Weight:** Less than 0.2 ounces



Model DDS100: Elapsed Time Indicator

Model DDS101: Event Counter

### ENVIRONMENTAL SPECIFICATIONS

**Operating Temperature Range:** -65 to +125°C

**Shock:** MIL-STD-202, Method 213, Condition I

**Vibration:** MIL-STD-202, Method 204, Condition D

**Life Accuracy:** ±0.1% from -65 to +125°C and 4.5 to 10 VDC

**Power Consumption:** 5 VDC

### ELECTRICAL SPECIFICATIONS

The meters meet or exceed applicable requirements of MIL-M-7793 and M7793/13.

**Operating Voltage Range:** 4.5 to 10 VDC

**Ripple Voltage:** 2 volt peak (4 volt peak-to-peak) ripple between 10Hz and 10kHz superimposed on 7.0 VDC

**Output Impedance:** 100kΩ ± 10%

**Logic Zero:** Between 0.0 and +0.2 volts

**Logic One:** Between +3.3 and +6.6 volts

**Power Consumption:** 2 milliwatts, max.

**Transient Protection:** Operation when subjected to ±25 volt transients of 10 microsecond duration occurring at a 1 millisecond repetition rate

**Dielectric:** Withstands 600 VRMS (room) and 350 VRMS (altitude) applied between the power terminals (+5 VDC and common) and an external ground that contact the meter case on the five sides without terminals

**Insulation Resistance:** MIL-STD-202, Method 302, Cond. B

**Accuracy:** 0.1% over temperature/voltage range

**Output Data:** Serial binary coded decimal format

This page consists of basic marketing information that is not defined as technical data under FAR Part 772.

# ELAPSED TIME INDICATORS & EVENT COUNTERS SOLID-STATE, PC BOARD MOUNT

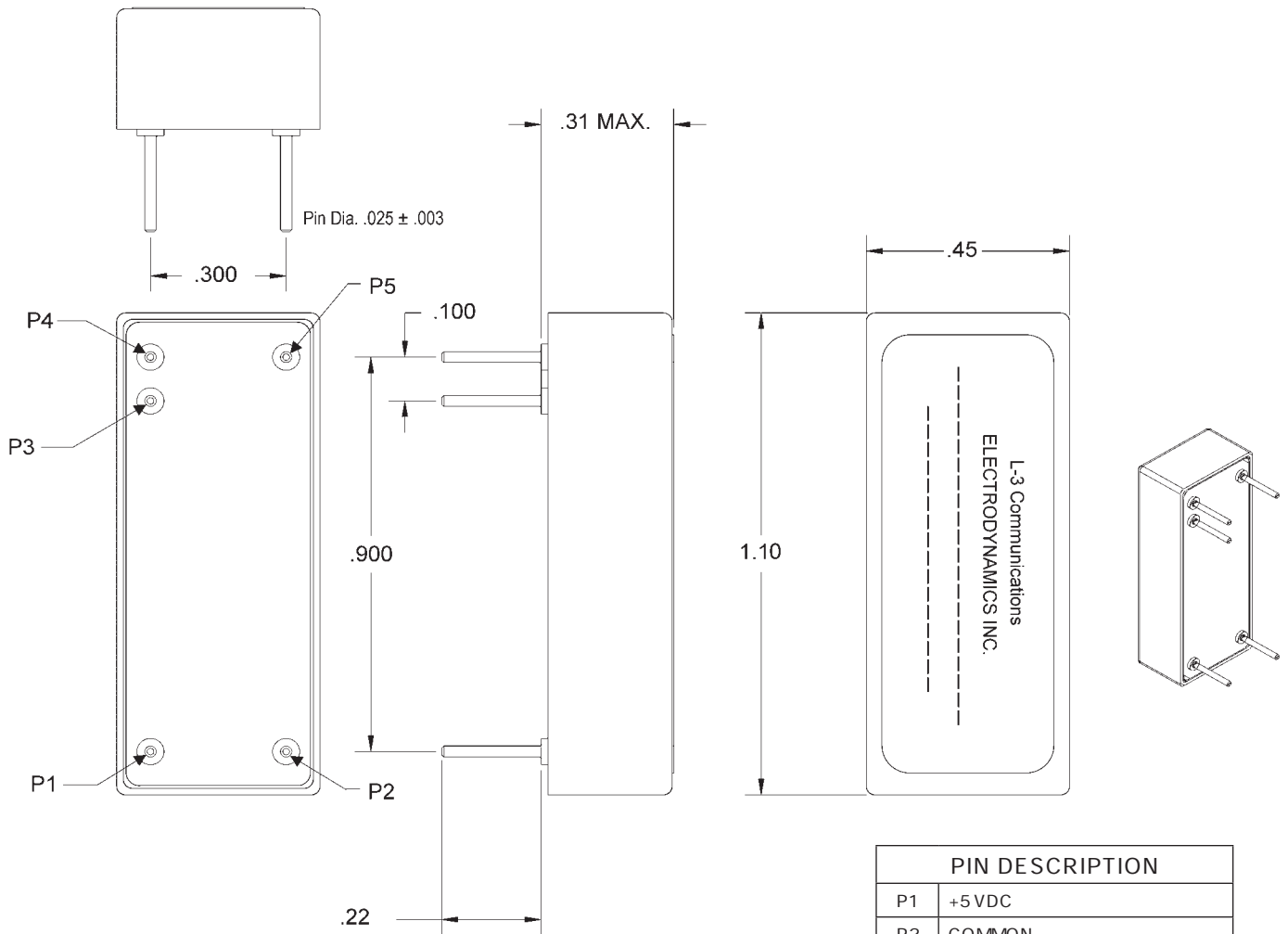

PIN DESCRIPTION	
P1	+5VDC
P2	COMMON
P3	OUTPUT DATA TO READER
P4	INPUT FROM READER (+5V)
P5	COMMON

Common pins are internally connected

DDS100 and DDS101

NOTE:  
Dimensions in inches.  
Tolerances, decimals: ±.02 for two-place decimals;  
±.015 for three-place decimals.

This page consists of basic marketing information that is not defined as technical data under EAR Part 772.

# ELAPSED TIME INDICATORS & EVENT COUNTERS RS232 PC BOARD MOUNT



ELAPSED TIME INDICATORS & EVENT COUNTERS

## Digital Series Models DDS232H & DDS232C

### DDS232H Elapsed Time Indicator Model

DDS232H Solid-State Elapsed Time Indicators have been developed to meet the most difficult requirements of many military and aerospace applications. In one PCB mount package, the DDS232H provides a highly reliable means of monitoring the system and provides an RS232/TTL output making it more compatible with industry standard electronic system design. It requires an RS232 driver/receiver chip such as a MAX232 for RS232 operation.

The indicator operates with 4.5 to 10 VDC and has a range of 99999.99 hours. In addition, the DDS232H has been tested to the MIL-M-7793/13 specification and can be applied to any severe environment.

### DDS232C Event Counter Model

The DDS232C Solid-State Event Counter records counts when the unit receives power for greater than 5 seconds. Power-on times of less than 4 seconds will not cause the counter to increment, allowing the count to be read without affecting the results. The count range is 9,999,999.

All connections, data collection, and the display of counts are made in the same manner as the DDS232H Elapsed Time Indicator.

### FEATURES

- Monitors your system usage
- RS232/TTL output
- PCB mount
- Non-volatile memory
- Meets mechanical and environmental characteristics of MIL-M-7793/13

### MECHANICAL SPECIFICATIONS

**Case Dimensions:** 1.1" long x .450" wide x .275" high

**Weight:** Less than 0.2 ounces



Model DDS232H: Elapsed Time Indicator  
Model DDS232C: Event Counter

### ENVIRONMENTAL SPECIFICATIONS

**Operating Temperature Range:** -65 to +125°C

**Shock:** MIL-STD-202, Method 213, Condition I

**Vibration:** MIL-STD-202, Method 204, Condition D

**Life Accuracy:** ±0.1% from -65 to +125°C and 4.5 to 10 VDC

**Power Consumption:** 2 mW max @ 5 VDC0.1

### ELECTRICAL SPECIFICATIONS

The meters meet or exceed applicable requirements of MIL-M-7793 and M7793/13.

**Operating Voltage Range:** 4.5 to 10 VDC

**Ripple Voltage:** 2 volt peak (4 volt peak-to-peak) ripple between 10Hz and 10kHz superimposed on 7.0 VDC

**Output Impedance:** 465Ω ± 10%

**Logic Zero:** Between 0.0 and +0.26 volts

**Logic One:** Between +3.3 and +4.5 volts

**Power Consumption:** 2 milliwatts, max.

**Transient Protection:** Operation when subjected to ±25 volt transients of 10 microsecond duration occurring at a 1 millisecond repetition rate

**Dielectric:** Withstands 600 VRMS (room) and 350 VRMS (altitude) applied between the power terminals (+5 VDC and common) and an external ground that contact the meter case on the five sides without terminals

**Insulation Resistance:** MIL-STD-202, Method 302, Cond. B

**Accuracy:** 0.1% over temperature/voltage range

**Output Data:** RS232/TTL, ASCII

This page consists of basic marketing information that is not defined as technical data under FAR Part 772.

# ELAPSED TIME INDICATORS & EVENT COUNTERS RS232 PC BOARD MOUNT

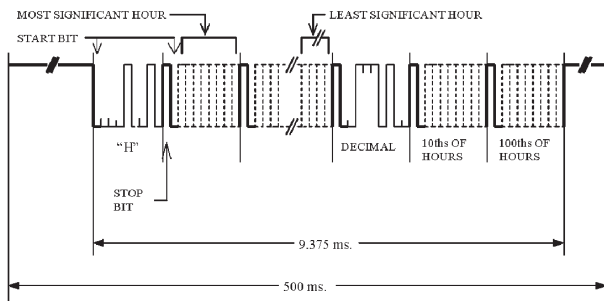
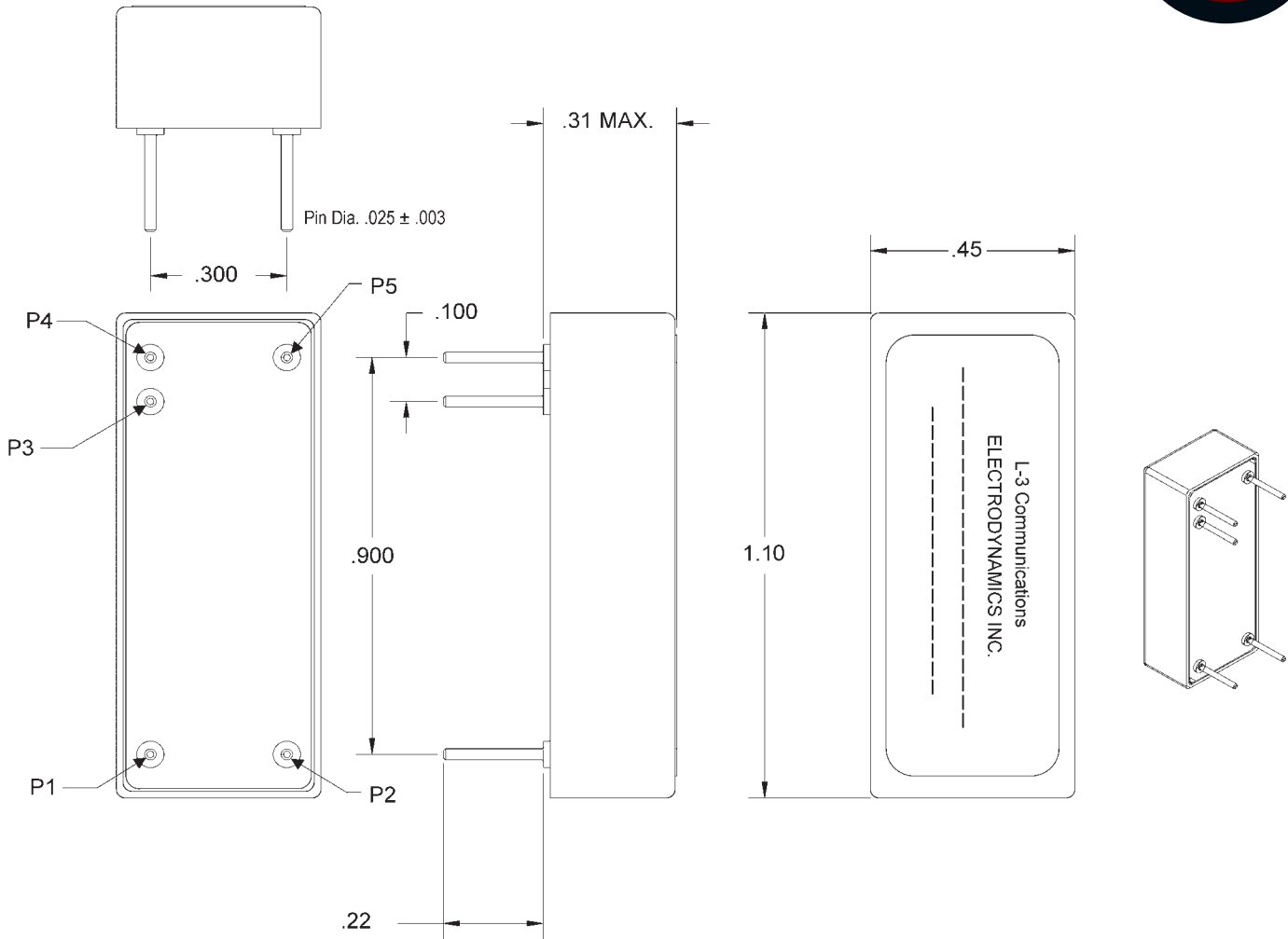

OUTPUT IS CONTINUOUS WHEN POWER IS APPLIED DATA RATE = 9600 BAUD

UART COMPATIBLE - OUTPUT REQUIRES A LEVEL SHIFTING DEVICE SUCH AS A MAX232

### DDS232H OUTPUT DATA FORMAT (ASCII)

PIN DESCRIPTION	
P1	+5 VDC
P2	COMMON
P3	OUTPUT DATA TO READER
P4	INPUT FROM READER (+5 V)
P5	COMMON

Common pins are internally connected

### DDS232H and DDS232C

NOTE:  
Dimensions in inches.  
Tolerances, decimals: ±.02 for two-place decimals;  
±.015 for three-place decimals.

This page consists of basic marketing information that is not defined as technical data under EAR Part 772.

ELAPSED TIME INDICATORS & EVENT COUNTERS

# ELAPSED TIME INDICATORS & EVENT COUNTERS SOLID-STATE, PANEL MOUNT



ELAPSED TIME INDICATORS & EVENT COUNTERS

## Digital Series Models DDS200 & DDS201

### DDS200 Elapsed Time Indicator Model

The DDS200 Solid-State Elapsed Time Indicator and the DDS201 Solid-State Event Counter have been developed to meet the most difficult requirements of military and aerospace applications. In one panel mount package, the DDS200 series provides a highly reliable means of monitoring critical system usage, important for proper equipment maintenance.

The elapsed time and events data can be read via the M7793/12 reader.

The time range for the DDS200 Elapsed Time Indicator is 99999.99 hours.

### DDS201 Event Counter Model

The DDS201 Solid-State Event Counter meets the electrical, mechanical and environment requirements of MIL-M-7793/14 and records counts when the unit receives power for greater than 5 seconds. Power-on times of less than 4 seconds will not cause the counter to increment. The count range is 9,999,999.

### FEATURES

- Monitors your system usage
- Meets MIL-M-7793/14
- Panel mount configuration
- MIL-M-7793/14 qualified model is also available.
- Non-volatile memory

### MECHANICAL SPECIFICATIONS

**Case Dimensions:** See next page for detailed dimensions

**Weight:** 1 ounce max.

**Elapsed Time Indicator—Time Range:** 99999.99 hours

### ENVIRONMENTAL SPECIFICATIONS

**Operating Temperature Range:** -65 to +125°C

**Shock:** MIL-STD-202, Method 213, Condition I

**Vibration:** MIL-STD-202, Method 204, Condition D

**Salt Spray:** MIL-STD-202, Method 101, Condition B

**Moisture Resistance:** MIL-STD-202, Method 106, Figure 106-1

**Altitude:** MIL-STD-202, Method 105, 0-80,000 feet



Model DDS200: Elapsed Time Indicator

Model DDS201: Event Counter

### ELECTRICAL SPECIFICATIONS

These meters meet or exceed applicable requirements of MIL-M-7793 and M7793/14.

**Operating Voltage Range:** 10-34 VDC and 20-30 VAC, 50-2400Hz

**Ripple Voltage:** Operates normally when subjected to a cyclic peak of ripple voltage of less than 2.0 VDC and the frequency-voltage coordinates of Figure 2 of MIL-DTL-7793/14

**Output Impedance:** 100kΩ ± 10%

**Logic Zero:** 0.0 to 0.2 V

**Logic One:** 3.3 to 6.6 V

**Power Consumption:** 50mW max. at 28 VDC; 25 mW max. at 26 VAC 400Hz

**Transient Protection:** Input voltage and time values shown on Figure 5 and Figure 6 (80V and 600V transient respectively) of MIL-DTL-7793/14.

**Dielectric:** Withstands 600 VRMS (room) and 350 VRMS (altitude) applied between the power terminals and an external ground

**Insulation Resistance:** MIL-STD-202, Method 302, Condition B

**Accuracy:** ±0.1% over temperature/voltage range

**EMC:** MIL-STD-461, Test Methods CE102 and RE102.

**Output Data:** Serial binary coded decimal format

**Reading Allowed at time of Shipments:** Meters can be delivered with +/- 1 hour upon delivery per MIL-DTL-7793

This page consists of basic marketing information that is not defined as technical data under FAR Part 772.

# ELAPSED TIME INDICATORS & EVENT COUNTERS SOLID-STATE, PANEL MOUNT

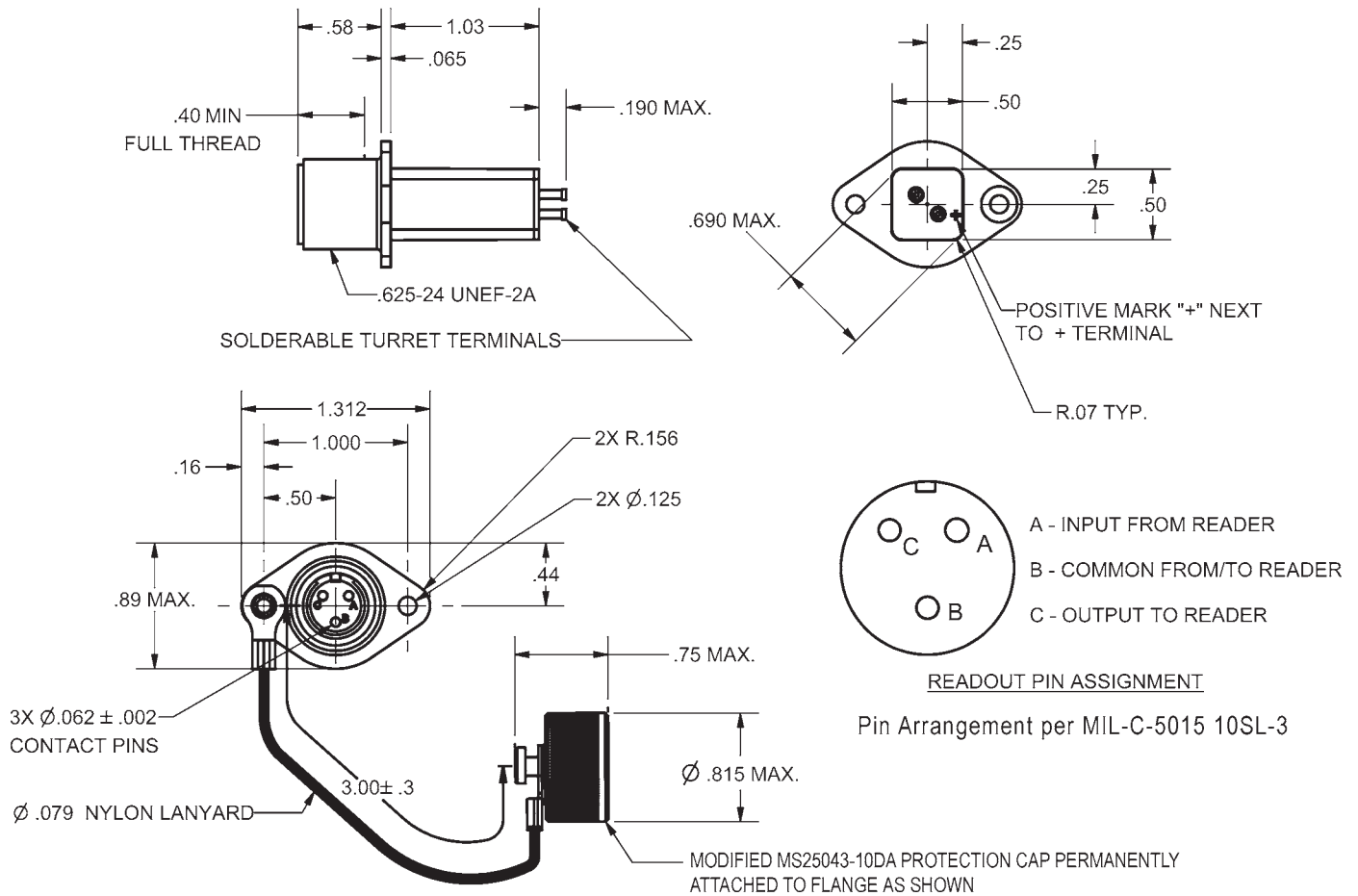

DDS200 and DDS201

NOTE:  
Dimensions in inches.  
Tolerances, decimals:  $\pm$ .02 for two-place decimals;  
 $\pm$ .015 for three-place decimals.

This page consists of basic marketing information that is not defined as technical data under EAR Part 772.

# SSETI READER FOR SOLID-STATE, PANEL MOUNT



ELAPSED TIME INDICATORS & EVENT COUNTERS

## Model 1170-004

For model DDS200 Solid-State Elapsed Time Indicators and model DDS201 Solid-State Event Counters

Model 1170-004 is compatible with the M7793/12 reader

### MECHANICAL SPECIFICATIONS

**Case Dimensions:** See below for detail dimensions

**Weight:** 15 ounce max. including battery

### ENVIRONMENTAL SPECIFICATIONS

**Operating Temperature Range:**

Continuous Operation: -20°C to +55°C

**Storage Temperature Range:** -30°C to +80°C

**Accuracy:** ±0.5% (max. deviation for the display)

**Shock:** MIL-STD-202E, Method 213B, Test Condition G, 50 Gs Peak, 11 millisecond sawtooth.

**Vibration:** MIL-STD-202E, Method 201A, 10 to 55Hz, 0.06 inch double amplitude.

**Power Source:** 9 Volt alkaline manganese primary battery (NEDA 1604)

**Battery Life:** 1200 readings or 2 years (whichever comes first), at 25°C

**Power Consumption:** Discharge current shall not exceed 80 ma at any time during operational cycle; 2 µA when non-operational.

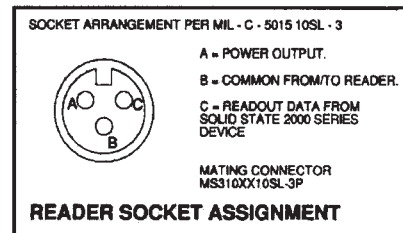
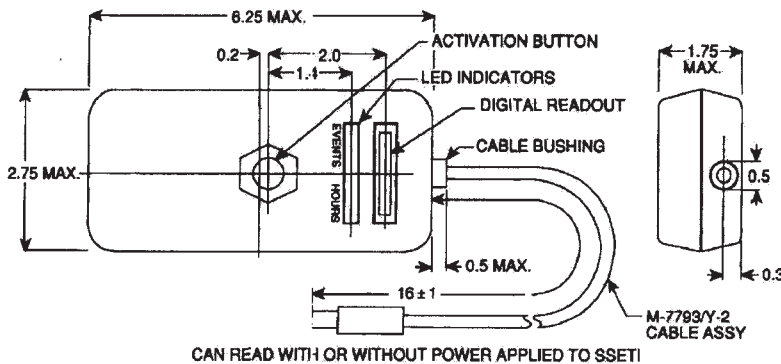

This page consists of basic marketing information that is not defined as technical data under FAR Part 772.